

Комбинированные печи GCE версия Т

Технические характеристики

По вопросам продаж и поддержки обращайтесь:

Алматы (727)345-47-04
Ангарск (3955)60-70-56
Архангельск (8182)63-90-72
Астрахань (8512)99-46-04
Барнаул (3852)73-04-60
Белгород (4722)40-23-64
Благовещенск (4162)22-76-07
Брянск (4832)59-03-52
Владивосток (423)249-28-31
Владикавказ (8672)28-90-48
Владимир (4922)49-43-18
Волгоград (844)278-03-48
Вологда (8172)26-41-59
Воронеж (473)204-51-73
Екатеринбург (343)384-55-89

Иваново (4932)77-34-06
Ижевск (3412)26-03-58
Иркутск (395)279-98-46
Казань (843)206-01-48
Калининград (4012)72-03-81
Калуга (4842)92-23-67
Кемерово (3842)65-04-62
Киров (8332)68-02-04
Коломна (4966)23-41-49
Кострома (4942)77-07-48
Краснодар (861)203-40-90
Красноярск (391)204-63-61
Курск (4712)77-13-04
Курган (3522)50-90-47
Липецк (4742)52-20-81

Магнитогорск (3519)55-03-13
Москва (495)268-04-70
Мурманск (8152)59-64-93
Набережные Челны (8552)20-53-41
Нижний Новгород (831)429-08-12
Новокузнецк (3843)20-46-81
Ноябрьск (3496)41-32-12
Новосибирск (383)227-86-73
Омск (3812)21-46-40
Орел (4862)44-53-42
Оренбург (3532)37-68-04
Пенза (8412)22-31-16
Петрозаводск (8142)55-98-37
Псков (8112)59-10-37
Пермь (342)205-81-47

Ростов-на-Дону (863)308-18-15
Рязань (4912)46-61-64
Самара (846)206-03-16
Санкт-Петербург (812)309-46-40
Саратов (845)249-38-78
Севастополь (8692)22-31-93
Саранск (8342)22-96-24
Симферополь (3652)67-13-56
Смоленск (4812)29-41-54
Сочи (862)225-72-31
Ставрополь (8652)20-65-13
Сургут (3462)77-98-35
Сыктывкар (8212)25-95-17
Тамбов (4752)50-40-97
Тверь (4822)63-31-35

Тольятти (8482)63-91-07
Томск (3822)98-41-53
Тула (4872)33-79-87
Тюмень (3452)66-21-18
Ульяновск (8422)24-23-59
Улан-Удэ (3012)59-97-51
Уфа (347)229-48-12
Хабаровск (4212)92-98-04
Чебоксары (8352)28-53-07
Челябинск (351)202-03-61
Череповец (8202)49-02-64
Чита (3022)38-34-83
Якутск (4112)23-90-97
Ярославль (4852)69-52-93

Россия +7(495)268-04-70

Казахстан +7(727)345-47-04

Беларусь +(375)257-127-884

Узбекистан +998(71)205-18-59

Киргизия +996(312)96-26-47

эл.почта: meo@nt-rt.ru || сайт: <https://module.nt-rt.ru/>

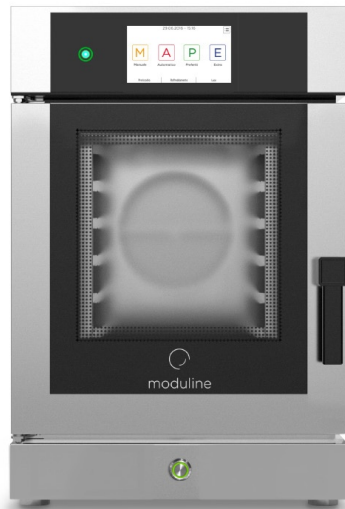

COMBI GCE060T Combi oven

CONSTRUCTION FEATURES

- Tightness chamber with radiused corners
- Total thermic insulation with rock or glass wool
- Long lasting front seals made up of food grade of high heat resistance
- Removable side racks to facilitate cleaning
- Internal drain for easy cleaning
- Ventilated heating provided by high efficiency protected heating elements

- Snap-shut door
- Adjustable feet
- Easy access to facilitate maintenance and repair
- Double low-emission glass door with internal ventilation
- Openable inside glass of the door
- Condensation drip tray under the door and connected to the oven drainage system.

FUNCTIONAL FEATURES

- Electronic control panel - 7" capacitive multitouch
- Simplified, user-friendly controls
- Periodic reversal of direction of rotation of the fan for better air distribution
- Automatic stopping of fans when the door is opened
- End-of-cycle buzzer
- Chamber with safety thermostat
- Operating temperature: from 30°C to 280°C in Convection mode, from 30°C to 280°C in Mixed Steam - Convection mode, from 30°C to 130°C in Direct Steam mode
- The cooking program can be divided into different phases
- Delta T function
- Consumption analysis function
- Automatic humidity exhaust system after cooking
- Self-diagnosis system
- Automatic telemetric registration system
- Steam condensation system
- Chamber cooling program
- USB port: software, HACCP data and recipes always at your fingertips and keeping up with the work evolution.
- EcoWash self-cleaning system

- Recipe Mix feature: once you set a program or choose a recipe, Combi suggests the food than can be cooked together to optimize time and cooking loads.
- MultiLevel function: Combi is able to manage different dishes with different cooking times or temperatures
- IdealWarm function: the intelligent temperature decrease in the cavity at the end of the cooking cycle allows perfect warm holding
- Climachef system
- FlashDry instant dehumidification function of the chamber.
- SpeedGrade fan speed adjustment
- The adaptive system for the energy calibration of the FitPower function adjusts and optimizes energy consumption based on usage.
- PadLock: key lock system with password
- ProTime system allows you to set the date and the time you want the oven to preheat or start working.
- SD Card: memory expansion with built-in SD card slot
- Multipoint core probe
- Glazed door plus lighting
- Removable GN2/3 tray racks

OPTIONS & ACCESSORIES

- Supports
- Needle core probe, thin
- Single-point core probe
- External hand shower
- Built-in sliding kit

- Wall brackets kit
- Stacking kit
- Water filter system
- Detergent/Rinsing agent
- Grids
- Trays

- Sound silencer
- Air condensation hood
- Opposite side opening
- Integral quenching system
- Door lock with key
- Power surge control set-up

TECHNICAL INSTALLATION DIAGRAM

Electricity supply
cable inlet



Safety vent
humidity



Chamber drain



Softened
water inlet



Adjustable vent for
excess humidity



Important - Drawing and
dimensions refer to the
standard version.
They may change with the
addition of accessories or
options.

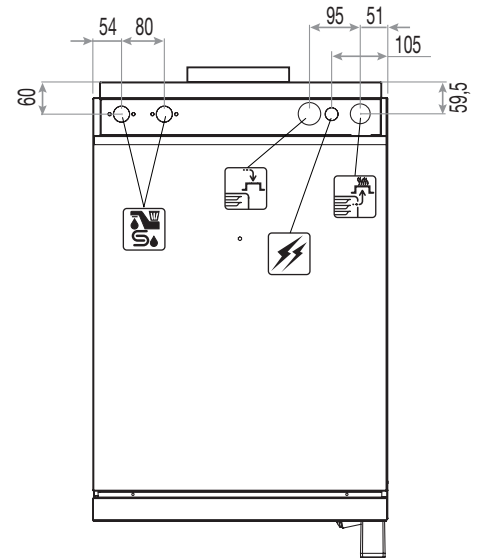
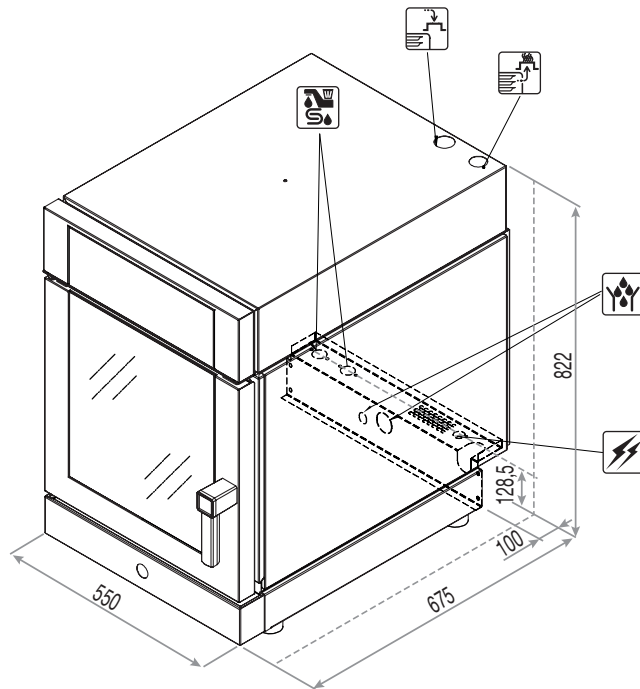

Overall dimensions
(W x D x H) - mm

550 x 675 x 822h

Product max
capacity [Kg]

10

Trays capacity

6 x GN 2/3

Total input
[kW]

5,45 (400V)

Distance
[mm]

64

Amps.
[A]

7,9 (400V)

Power supply

380-415V 3N 50/60Hz

Water pressure
[kPa]

150 ÷ 500

Working
temperature [°C]

30 ÷ 280

Net weight
[Kg]

65

Status reporting LED
/ stand-by key



7" capacitive multitouch easy-to-browse display

- Temperature control from 30°C to 280°C
- Time control
- 3 Cooking modes: convection, steam, combined convection - steam
- Automatic cooking programs divided into 6 categories
- Ability to manage up to 10 cooking phases for each program
- Favourite programs section
- Cooking with core probe
- Cooking mode with delta-t
- Climate control in the cavity with climachef system
- Recipe book customised with pictures
- Speedgrade: fans speed control
- Special features: multilevel, recipemix, idealwarm, flashdry, fitpower, protime, padlock, ecowash

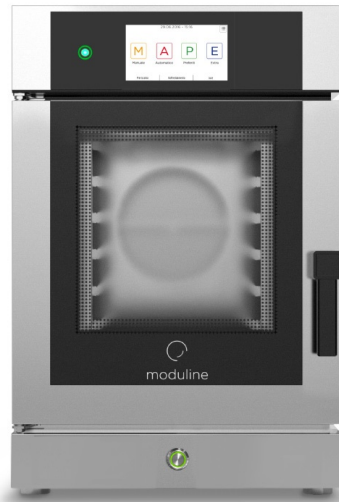

COMBI GCE106T Combi oven

CONSTRUCTION FEATURES

- Tightness chamber with radiused corners
- Total thermic insulation with rock or glass wool
- Long lasting front seals made up of food grade of high heat resistance
- Removable side racks to facilitate cleaning
- Internal drain for easy cleaning
- Ventilated heating provided by high efficiency protected heating elements
- Snap-shut door
- Adjustable feet
- Easy access to facilitate maintenance and repair
- Double low-emission glass door with internal ventilation
- Openable inside glass of the door
- Condensation drip tray under the door and connected to the oven drainage system.





FUNCTIONAL FEATURES

- Electronic control panel - 7" capacitive multitouch
- Simplified, user-friendly controls
- Periodic reversal of direction of rotation of the fan for better air distribution
- Automatic stopping of fans when the door is opened
- End-of-cycle buzzer
- Chamber with safety thermostat
- Operating temperature: from 30°C to 280°C in Convection mode, from 30°C to 280°C in Mixed Steam - Convection mode, from 30°C to 130°C in Direct Steam mode
- The cooking program can be divided into different phases
- Delta T function
- Consumption analysis function
- Automatic humidity exhaust system after cooking
- Self-diagnosis system
- Automatic telemetric registration system
- Steam condensation system
- Chamber cooling program
- USB port: software, HACCP data and recipes always at your fingertips and keeping up with the work evolution.
- EcoWash self-cleaning system
- Recipe Mix feature: once you set a program or choose a recipe, Combi suggests the food than can be cooked together to optimize time and cooking loads.
- MultiLevel function: Combi is able to manage different dishes with different cooking times or temperatures
- IdealWarm function: the intelligent temperature decrease in the cavity at the end of the cooking cycle allows perfect warm holding
- Climachef system
- FlashDry instant dehumidification function of the chamber.
- SpeedGrade fan speed adjustment
- The adaptive system for the energy calibration of the FitPower function adjusts and optimizes energy consumption based on usage.
- PadLock: key lock system with password
- ProTime system allows you to set the date and the time you want the oven to preheat or start working.
- SD Card: memory expansion with built-in SD card slot
- Multipoint core probe
- Glazed door plus lighting
- Removable GN1/1 tray racks

OPTIONS & ACCESSORIES

- | | | |
|--|--|---|
| <input type="checkbox"/> Supports | <input type="checkbox"/> Water filter system | <input type="checkbox"/> Air condensation hood |
| <input type="checkbox"/> Needle core probe, thin | <input type="checkbox"/> Detergent/Rinsing agent | <input type="checkbox"/> Opposite side opening |
| <input type="checkbox"/> Single-point core probe | <input type="checkbox"/> Grids | <input type="checkbox"/> Integral quenching system |
| <input type="checkbox"/> External hand shower | <input type="checkbox"/> Trays | <input type="checkbox"/> Door lock with key |
| <input type="checkbox"/> Stacking kit | <input type="checkbox"/> Sound silencer | <input type="checkbox"/> Power surge control set-up |

TECHNICAL INSTALLATION DIAGRAM

- Electricity supply cable inlet 
- Safety vent humidity 
- Chamber drain 
- Softened water inlet 
- Adjustable vent for excess humidity 

Important - Drawing and dimensions refer to the standard version. They may change with the addition of accessories or options.

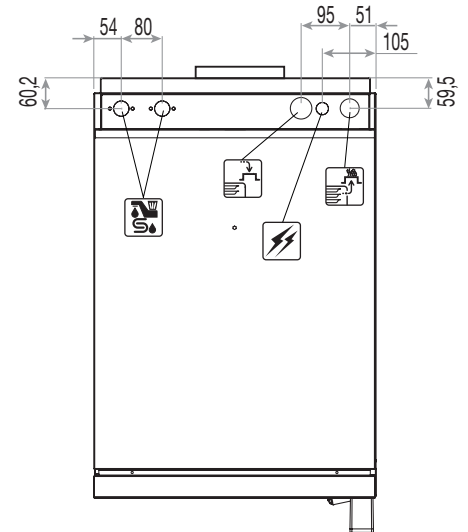
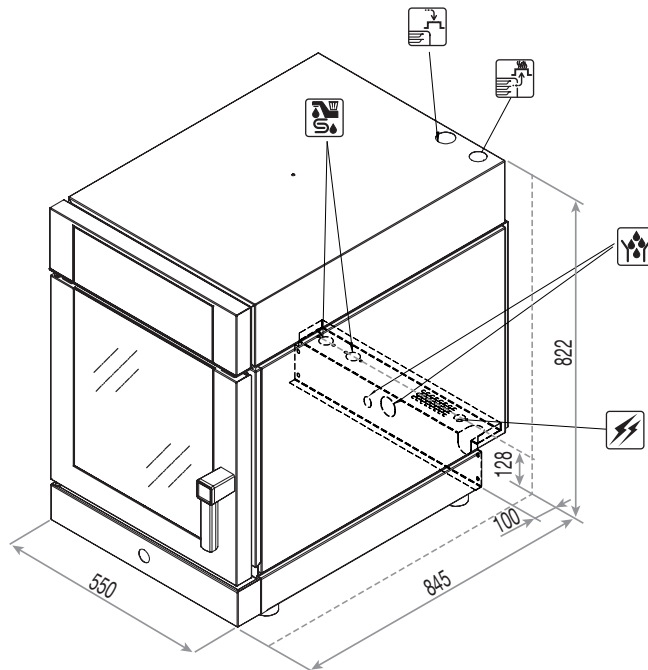

Overall dimensions (W x D x H) - mm	550 x 845 x 822h	Product max capacity [Kg]	15
Trays capacity	6 x GN 1/1	Total input [kW]	7,95 (400V)
Distance [mm]	64	Amps. [A]	11,5 (400V)
Power supply	380-415V 3N 50/60Hz	Water pressure [kPa]	150 ÷ 500
Working temperature [°C]	30 ÷ 280	Net weight [Kg]	90

Status reporting LED / stand-by key



7" capacitive multitouch easy-to-browse display

- Temperature control from 30°C to 280°C
- Time control
- 3 Cooking modes: convection, steam, combined convection - steam
- Automatic cooking programs divided into 6 categories
- Ability to manage up to 10 cooking phases for each program
- Favourite programs section
- Cooking with core probe
- Cooking mode with delta-t
- Climate control in the cavity with climachef system
- Recipe book customised with pictures
- Speedgrade: fans speed control
- Special features: multilevel, recipemix, idealwarm, flashdry, fitpower, protime, padlock, ecowash

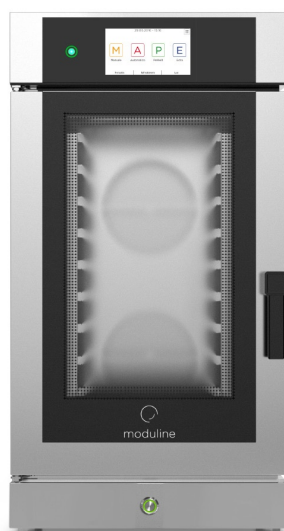

COMBI GCE110T Combi oven

CONSTRUCTION FEATURES

- Tightness chamber with radiused corners
- Total thermic insulation with rock or glass wool
- Long lasting front seals made up of food grade of high heat resistance
- Removable side racks to facilitate cleaning
- Internal drain for easy cleaning
- Ventilated heating provided by high efficiency protected heating elements

- Snap-shut door
- Adjustable feet
- Easy access to facilitate maintenance and repair
- Double low-emission glass door with internal ventilation
- Openable inside glass of the door
- Condensation drip tray under the door and connected to the oven drainage system.

FUNCTIONAL FEATURES





- Electronic control panel - 7" capacitive multitouch
- Simplified, user-friendly controls
- Periodic reversal of direction of rotation of the fan for better air distribution
- Automatic stopping of fans when the door is opened
- End-of-cycle buzzer
- Chamber with safety thermostat
- Operating temperature: from 30°C to 280°C in Convection mode, from 30°C to 280°C in Mixed Steam - Convection mode, from 30°C to 130°C in Direct Steam mode
- The cooking program can be divided into different phases
- Delta T function
- Consumption analysis function
- Automatic humidity exhaust system after cooking
- Self-diagnosis system
- Automatic telemetric registration system
- Steam condensation system
- Chamber cooling program
- USB port: software, HACCP data and recipes always at your fingertips and keeping up with the work evolution.
- EcoWash self-cleaning system

- Recipe Mix feature: once you set a program or choose a recipe, Combi suggests the food than can be cooked together to optimize time and cooking loads.
- MultiLevel function: Combi is able to manage different dishes with different cooking times or temperatures
- IdealWarm function: the intelligent temperature decrease in the cavity at the end of the cooking cycle allows perfect warm holding
- Climachef system
- FlashDry instant dehumidification function of the chamber.
- SpeedGrade fan speed adjustment
- The adaptive system for the energy calibration of the FitPower function adjusts and optimizes energy consumption based on usage.
- PadLock: key lock system with password
- ProTime system allows you to set the date and the time you want the oven to preheat or start working.
- SD Card: memory expansion with built-in SD card slot
- Multipoint core probe
- Glazed door plus lighting
- Removable GN1/1 tray racks

OPTIONS & ACCESSORIES

- | | | |
|--|--|---|
| <input type="checkbox"/> Supports | <input type="checkbox"/> Detergent/Rinsing agent | <input type="checkbox"/> Air condensation hood |
| <input type="checkbox"/> Needle core probe, thin | <input type="checkbox"/> Grids | <input type="checkbox"/> Opposite side opening |
| <input type="checkbox"/> Single-point core probe | <input type="checkbox"/> Trays | <input type="checkbox"/> Integral quenching system |
| <input type="checkbox"/> External hand shower | <input type="checkbox"/> Sound silencer | <input type="checkbox"/> Door lock with key |
| <input type="checkbox"/> Water filter system | | <input type="checkbox"/> Power surge control set-up |

TECHNICAL INSTALLATION DIAGRAM

- Electricity supply cable inlet 
- Safety vent humidity 
- Chamber drain 
- Softened water inlet 
- Adjustable vent for excess humidity 

Important - Drawing and dimensions refer to the standard version. They may change with the addition of accessories or options.

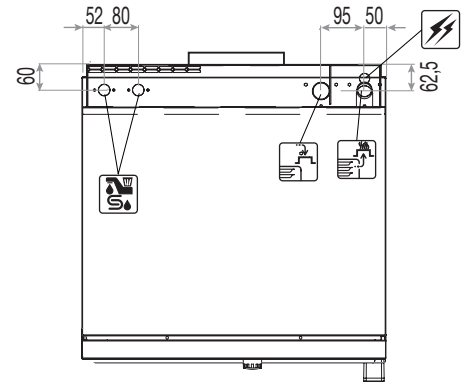
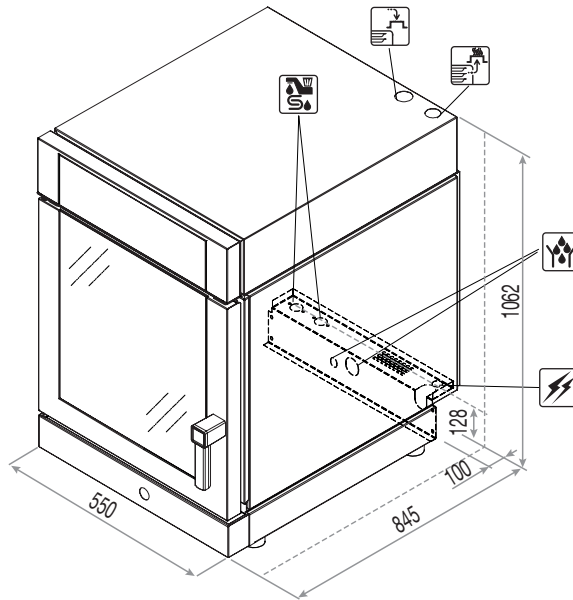

Overall dimensions (W x D x H) - mm	550 x 845 x 1062h	Product max capacity [Kg]	24
Trays capacity	10 x GN 1/1	Total input [kW]	12,65 (400V)
Distance [mm]	64	Amps. [A]	18,3 (400V)
Power supply	380-415V 3N 50/60Hz	Water pressure [kPa]	150 ÷ 500
Working temperature [°C]	30 ÷ 280	Net weight [Kg]	100

Status reporting LED / stand-by key



7" capacitive multitouch easy-to-browse display

- Temperature control from 30°C to 280°C
- Time control
- 3 Cooking modes: convection, steam, combined convection - steam
- Automatic cooking programs divided into 6 categories
- Ability to manage up to 10 cooking phases for each program
- Favourite programs section
- Cooking with core probe
- Cooking mode with delta-t
- Climate control in the cavity with climachef system
- Recipe book customised with pictures
- Speedgrade: fans speed control
- Special features: multilevel, recipemix, idealwarm, flashdry, fitpower, protime, padlock, ecowash



COMBI GCE061T Combi oven

CONSTRUCTION FEATURES

- Tightness chamber with radiused corners
- Total thermic insulation with rock or glass wool
- Long lasting front seals made up of food grade of high heat resistance
- Removable side racks to facilitate cleaning
- Internal drain for easy cleaning
- Ventilated heating provided by high efficiency protected heating elements
- Snap-shut door
- Adjustable feet
- Easy access to facilitate maintenance and repair
- Double low-emission glass door with internal ventilation
- Openable inside glass of the door
- Condensation drip tray under the door and connected to the oven drainage system.

FUNCTIONAL FEATURES

- Electronic control panel - 7" capacitive multitouch
- Simplified, user-friendly controls
- Periodic reversal of direction of rotation of the fan for better air distribution
- Automatic stopping of fans when the door is opened
- End-of-cycle buzzer
- Chamber with safety thermostat
- Operating temperature: from 30°C to 280°C in Convection mode, from 30°C to 280°C in Mixed Steam - Convection mode, from 30°C to 130°C in Direct Steam mode
- The cooking program can be divided into different phases
- Delta T function
- Consumption analysis function
- Automatic humidity exhaust system after cooking
- Self-diagnosis system
- Automatic telemetric registration system
- Steam condensation system
- Chamber cooling program
- USB port: software, HACCP data and recipes always at your fingertips and keeping up with the work evolution.
- EcoWash self-cleaning system
- Recipe Mix feature: once you set a program or choose a recipe, Combi suggests the food than can be cooked together to optimize time and cooking loads.
- MultiLevel function: Combi is able to manage different dishes with different cooking times or temperatures
- IdealWarm function: the intelligent temperature decrease in the cavity at the end of the cooking cycle allows perfect warm holding
- Climachef system
- FlashDry instant dehumidification function of the chamber.
- SpeedGrade fan speed adjustment
- The adaptive system for the energy calibration of the FitPower function adjusts and optimizes energy consumption based on usage.
- PadLock: key lock system with password
- ProTime system allows you to set the date and the time you want the oven to preheat or start working.
- SD Card: memory expansion with built-in SD card slot
- Multipoint core probe
- Glazed door plus lighting
- Removable GN1/1 tray racks

OPTIONS & ACCESSORIES

- | | | |
|--|--|---|
| <input type="checkbox"/> Supports | <input type="checkbox"/> Stacking kit | <input type="checkbox"/> Air condensation hood |
| <input type="checkbox"/> Needle core probe, thin | <input type="checkbox"/> Water filter system | <input type="checkbox"/> Opposite side opening |
| <input type="checkbox"/> Single-point core probe | <input type="checkbox"/> Detergent/Rinsing agent | <input type="checkbox"/> Side racks 600x400 |
| <input type="checkbox"/> External hand shower | <input type="checkbox"/> Grids | <input type="checkbox"/> Integral quenching system |
| <input type="checkbox"/> Built-in sliding kit | <input type="checkbox"/> Trays | <input type="checkbox"/> Door lock with key |
| <input type="checkbox"/> Wall brackets kit | <input type="checkbox"/> Sound silencer | <input type="checkbox"/> Power surge control set-up |

TECHNICAL INSTALLATION DIAGRAM

Electricity supply
cable inlet 

Safety vent
humidity 

Chamber drain 

Softened
water inlet 

Adjustable vent for
excess humidity 

Important - Drawing and
dimensions refer to the
standard version.
They may change with the
addition of accessories or
options.

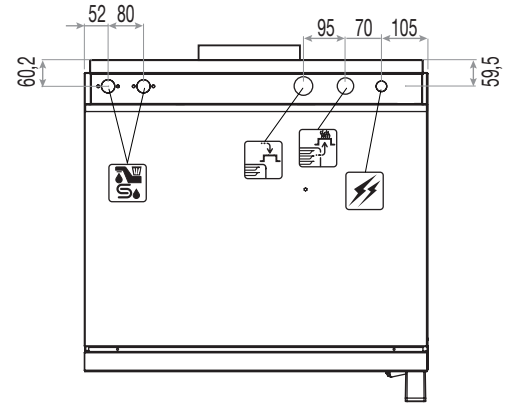
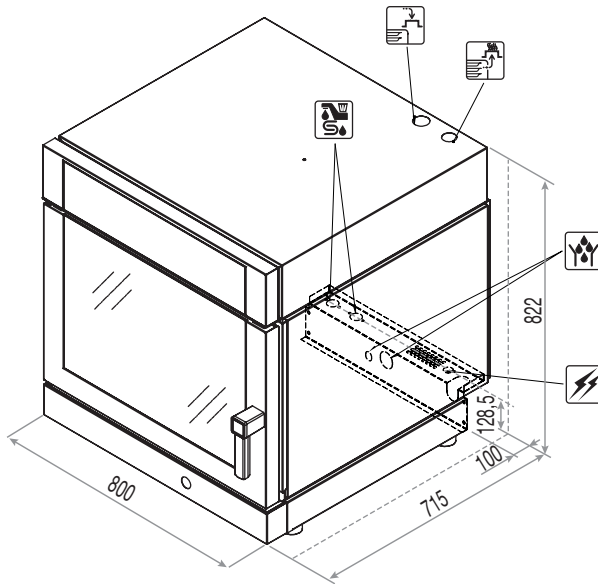

Overall dimensions
(W x D x H) - mm

800 x 715 x 822h

Product max
capacity [Kg]

15

Trays capacity

6 x GN 1/1
or 600x400

Total input
[kW]

7,95 (400V)

Distance
[mm]

64

Amps.
[A]

11,5 (400V)

Power supply

380-415V 3N 50/60Hz

Water pressure
[kPa]

150 ÷ 500

Working
temperature [°C]

30 ÷ 280

Net weight
[Kg]

90

Status reporting LED
/ stand-by key



7" capacitive multitouch easy-to-browse display

- Temperature control from 30°C to 280°C
- Time control
- 3 Cooking modes: convection, steam, combined convection - steam
- Automatic cooking programs divided into 6 categories
- Ability to manage up to 10 cooking phases for each program
- Favourite programs section
- Cooking with core probe
- Cooking mode with delta-t
- Climate control in the cavity with climachef system
- Recipe book customised with pictures
- Speedgrade: fans speed control
- Special features: multilevel, recipemix, idealwarm, flashdry, fitpower, protime, padlock, ecowash



COMBI GCE101T Combi oven

CONSTRUCTION FEATURES

- Tightness chamber with radiused corners
- Total thermic insulation with rock or glass wool
- Long lasting front seals made up of food grade of high heat resistance
- Removable side racks to facilitate cleaning
- Internal drain for easy cleaning
- Ventilated heating provided by high efficiency protected heating elements

- Snap-shut door
- Adjustable feet
- Easy access to facilitate maintenance and repair
- Double low-emission glass door with internal ventilation
- Openable inside glass of the door
- Condensation drip tray under the door and connected to the oven drainage system.

FUNCTIONAL FEATURES





- Electronic control panel - 7" capacitive multitouch
- Simplified, user-friendly controls
- Periodic reversal of direction of rotation of the fan for better air distribution
- Automatic stopping of fans when the door is opened
- End-of-cycle buzzer
- Chamber with safety thermostat
- Operating temperature: from 30°C to 280°C in Convection mode, from 30°C to 280°C in Mixed Steam - Convection mode, from 30°C to 130°C in Direct Steam mode
- The cooking program can be divided into different phases
- Delta T function
- Consumption analysis function
- Automatic humidity exhaust system after cooking
- Self-diagnosis system
- Automatic telemetric registration system
- Steam condensation system
- Chamber cooling program
- USB port: software, HACCP data and recipes always at your fingertips and keeping up with the work evolution.
- EcoWash self-cleaning system

- Recipe Mix feature: once you set a program or choose a recipe, Combi suggests the food that can be cooked together to optimize time and cooking loads.
- MultiLevel function: Combi is able to manage different dishes with different cooking times or temperatures
- IdealWarm function: the intelligent temperature decrease in the cavity at the end of the cooking cycle allows perfect warm holding
- Climachef system
- FlashDry instant dehumidification function of the chamber.
- SpeedGrade fan speed adjustment
- The adaptive system for the energy calibration of the FitPower function adjusts and optimizes energy consumption based on usage.
- PadLock: key lock system with password
- ProTime system allows you to set the date and the time you want the oven to preheat or start working.
- SD Card: memory expansion with built-in SD card slot
- Multipoint core probe
- Glazed door plus lighting
- Removable GN1/1 tray racks

OPTIONS & ACCESSORIES

- | | | |
|--|--|---|
| <input type="checkbox"/> Supports | <input type="checkbox"/> Detergent/Rinsing agent | <input type="checkbox"/> Opposite side opening |
| <input type="checkbox"/> Needle core probe, thin | <input type="checkbox"/> Grids | <input type="checkbox"/> Side racks 600x400 |
| <input type="checkbox"/> Single-point core probe | <input type="checkbox"/> Trays | <input type="checkbox"/> Integral quenching system |
| <input type="checkbox"/> External hand shower | <input type="checkbox"/> Sound silencer | <input type="checkbox"/> Door lock with key |
| <input type="checkbox"/> Water filter system | <input type="checkbox"/> Air condensation hood | <input type="checkbox"/> Power surge control set-up |

TECHNICAL INSTALLATION DIAGRAM

- Electricity supply cable inlet 
- Safety vent humidity 
- Chamber drain 
- Softened water inlet 
- Adjustable vent for excess humidity 

Important - Drawing and dimensions refer to the standard version. They may change with the addition of accessories or options.

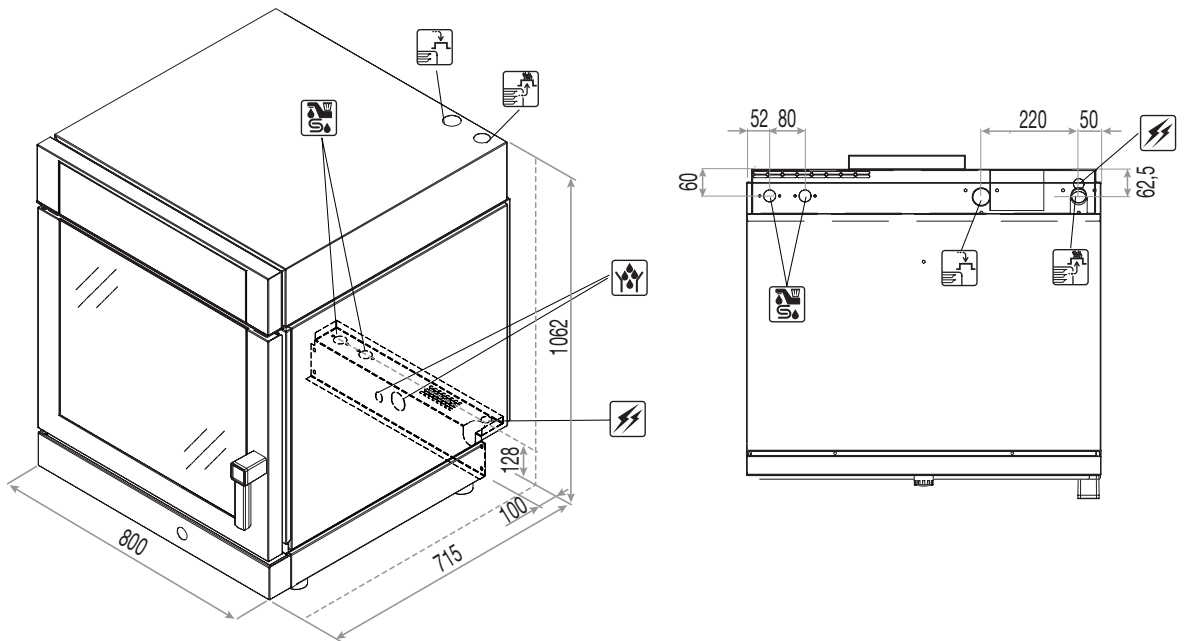

Overall dimensions (W x D x H) - mm

800 x 715 x 1062h

Product max capacity [Kg]

24

Trays capacity

10 x GN 1/1
or 600x400

Total input [kW]

15,65 (400V)

Distance [mm]

64

Amps. [A]

22,7 (400V)

Power supply

380-415V 3N 50/60Hz

Water pressure [kPa]

150 ÷ 500

Working temperature [°C]

30 ÷ 280

Net weight [Kg]

100

Status reporting LED / stand-by key



7" capacitive multitouch easy-to-browse display

- Temperature control from 30°C to 280°C
- Time control
- 3 Cooking modes: convection, steam, combined convection - steam
- Automatic cooking programs divided into 6 categories
- Ability to manage up to 10 cooking phases for each program
- Favourite programs section
- Cooking with core probe
- Cooking mode with delta-t
- Climate control in the cavity with climachef system
- Recipe book customised with pictures
- Speedgrade: fans speed control
- Special features: multilevel, recipemix, idealwarm, flashdry, fitpower, protime, padlock, ecowash

По вопросам продаж и поддержки обращайтесь:

Алматы (727)345-47-04
Ангарск (3955)60-70-56
Архангельск (8182)63-90-72
Астрахань (8512)99-46-04
Барнаул (3852)73-04-60
Белгород (4722)40-23-64
Благовещенск (4162)22-76-07
Брянск (4832)59-03-52
Владивосток (423)249-28-31
Владикавказ (8672)28-90-48
Владимир (4922)49-43-18
Волгоград (844)278-03-48
Вологда (8172)26-41-59
Воронеж (473)204-51-73
Екатеринбург (343)384-55-89

Иваново (4932)77-34-06
Ижевск (3412)26-03-58
Иркутск (395)279-98-46
Казань (843)206-01-48
Калининград (4012)72-03-81
Калуга (4842)92-23-67
Кемерово (3842)65-04-62
Киров (8332)68-02-04
Коломна (4966)23-41-49
Кострома (4942)77-07-48
Краснодар (861)203-40-90
Красноярск (391)204-63-61
Курск (4712)77-13-04
Курган (3522)50-90-47
Липецк (4742)52-20-81

Магнитогорск (3519)55-03-13
Москва (495)268-04-70
Мурманск (8152)59-64-93
Набережные Челны (8552)20-53-41
Нижний Новгород (831)429-08-12
Новокузнецк (3843)20-46-81
Ноябрьск (3496)41-32-12
Новосибирск (383)227-86-73
Омск (3812)21-46-40
Орел (4862)44-53-42
Оренбург (3532)37-68-04
Пенза (8412)22-31-16
Петрозаводск (8142)55-98-37
Псков (8112)59-10-37
Пермь (342)205-81-47

Ростов-на-Дону (863)308-18-15
Рязань (4912)46-61-64
Самара (846)206-03-16
Санкт-Петербург (812)309-46-40
Саратов (845)249-38-78
Севастополь (8692)22-31-93
Саранск (8342)22-96-24
Симферополь (3652)67-13-56
Смоленск (4812)29-41-54
Сочи (862)225-72-31
Ставрополь (8652)20-65-13
Сургут (3462)77-98-35
Сыктывкар (8212)25-95-17
Тамбов (4752)50-40-97
Тверь (4822)63-31-35

Тольятти (8482)63-91-07
Томск (3822)98-41-53
Тула (4872)33-79-87
Тюмень (3452)66-21-18
Ульяновск (8422)24-23-59
Улан-Удэ (3012)59-97-51
Уфа (347)229-48-12
Хабаровск (4212)92-98-04
Чебоксары (8352)28-53-07
Челябинск (351)202-03-61
Череповец (8202)49-02-64
Чита (3022)38-34-83
Якутск (4112)23-90-97
Ярославль (4852)69-52-93

Россия +7(495)268-04-70

Казахстан +7(727)345-47-04

Беларусь +(375)257-127-884

Узбекистан +998(71)205-18-59

Киргизия +996(312)96-26-47

эл.почта: meo@nt-rt.ru || сайт: <https://module.nt-rt.ru/>