

# Комбинированные печи GCE версия DW

## Технические характеристики

По вопросам продаж и поддержки обращайтесь:

Алматы (727)345-47-04  
Ангарск (3955)60-70-56  
Архангельск (8182)63-90-72  
Астрахань (8512)99-46-04  
Барнаул (3852)73-04-60  
Белгород (4722)40-23-64  
Благовещенск (4162)22-76-07  
Брянск (4832)59-03-52  
Владивосток (423)249-28-31  
Владикавказ (8672)28-90-48  
Владимир (4922)49-43-18  
Волгоград (844)278-03-48  
Вологда (8172)26-41-59  
Воронеж (473)204-51-73  
Екатеринбург (343)384-55-89

Иваново (4932)77-34-06  
Ижевск (3412)26-03-58  
Иркутск (395)279-98-46  
Казань (843)206-01-48  
Калининград (4012)72-03-81  
Калуга (4842)92-23-67  
Кемерово (3842)65-04-62  
Киров (8332)68-02-04  
Коломна (4966)23-41-49  
Кострома (4942)77-07-48  
Краснодар (861)203-40-90  
Красноярск (391)204-63-61  
Курск (4712)77-13-04  
Курган (3522)50-90-47  
Липецк (4742)52-20-81

Магнитогорск (3519)55-03-13  
Москва (495)268-04-70  
Мурманск (8152)59-64-93  
Набережные Челны (8552)20-53-41  
Нижний Новгород (831)429-08-12  
Новокузнецк (3843)20-46-81  
Ноябрьск (3496)41-32-12  
Новосибирск (383)227-86-73  
Омск (3812)21-46-40  
Орел (4862)44-53-42  
Оренбург (3532)37-68-04  
Пенза (8412)22-31-16  
Петрозаводск (8142)55-98-37  
Псков (8112)59-10-37  
Пермь (342)205-81-47

Ростов-на-Дону (863)308-18-15  
Рязань (4912)46-61-64  
Самара (846)206-03-16  
Санкт-Петербург (812)309-46-40  
Саратов (845)249-38-78  
Севастополь (8692)22-31-93  
Саранск (8342)22-96-24  
Симферополь (3652)67-13-56  
Смоленск (4812)29-41-54  
Сочи (862)225-72-31  
Ставрополь (8652)20-65-13  
Сургут (3462)77-98-35  
Сыктывкар (8212)25-95-17  
Тамбов (4752)50-40-97  
Тверь (4822)63-31-35

Тольятти (8482)63-91-07  
Томск (3822)98-41-53  
Тула (4872)33-79-87  
Тюмень (3452)66-21-18  
Ульяновск (8422)24-23-59  
Улан-Удэ (3012)59-97-51  
Уфа (347)229-48-12  
Хабаровск (4212)92-98-04  
Чебоксары (8352)28-53-07  
Челябинск (351)202-03-61  
Череповец (8202)49-02-64  
Чита (3022)38-34-83  
Якутск (4112)23-90-97  
Ярославль (4852)69-52-93

Россия +7(495)268-04-70

Казахстан +7(727)345-47-04

Беларусь +(375)257-127-884

Узбекистан +998(71)205-18-59

Киргизия +996(312)96-26-47

эл.почта: [meo@nt-rt.ru](mailto:meo@nt-rt.ru) || сайт: <https://module.nt-rt.ru/>

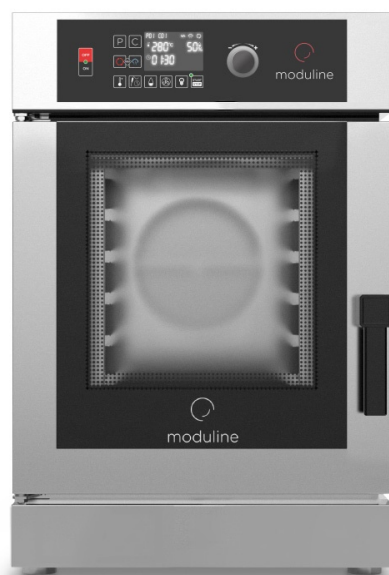

# COMBI GCE060DW

## Combi oven

### CONSTRUCTION FEATURES

- Tightness chamber with radiused corners
- Total thermic insulation with rock or glass wool
- Long lasting front seals made up of food grade of high heat resistance
- Removable side racks to facilitate cleaning
- Internal drain for easy cleaning
- Ventilated heating provided by high efficiency protected heating elements
- Snap-shut door
- Adjustable feet
- Easy access to facilitate maintenance and repair
- Double low-emission glass door with internal ventilation
- Openable inside glass of the door
- Condensation drip tray under the door and connected to the oven drainage system.

### FUNCTIONAL FEATURES

- Electronic control panel with digital display, keys and knob
- Simplified, user-friendly controls
- Periodic reversal of direction of rotation of the fan for better air distribution
- Automatic stopping of fans when the door is opened
- End-of-cycle buzzer
- Chamber with safety thermostat
- Operating temperature: from 30°C to 280°C in Convection mode, from 30°C to 280°C in Mixed Steam - Convection mode, from 30°C to 130°C in Direct Steam mode
- The cooking program can be divided into different phases
- Automatic humidity exhaust system after cooking
- Self-diagnosis system
- Steam condensation system
- Chamber cooling program
- IdealWarm function: the intelligent temperature decrease in the cavity at the end of the cooking cycle allows perfect warm holding
- Climachef system
- FlashDry instant dehumidification function of the chamber.
- PadLock: key lock system with password
- ProTime system allows you to set the date and the time you want the oven to preheat or start working.
- Glazed door plus lighting
- Removable GN2/3 tray racks
- EcoWash self-cleaning system

### OPTIONS & ACCESSORIES

- |  |  |  |
|--|--|--|
| <input type="checkbox"/> Supports                | <input type="checkbox"/> Wall brackets kit               | <input type="checkbox"/> Detergent/Rinsing agent |
| <input type="checkbox"/> Multipoint core probe   | <input type="checkbox"/> Stacking kit                    | <input type="checkbox"/> Grids                   |
| <input type="checkbox"/> Needle core probe, thin | <input type="checkbox"/> USB port                        | <input type="checkbox"/> Trays                   |
| <input type="checkbox"/> External hand shower    | <input type="checkbox"/> SpeedGrade fan speed adjustment | <input type="checkbox"/> Sound silencer          |
| <input type="checkbox"/> Built-in sliding kit    | <input type="checkbox"/> Water filter system             | <input type="checkbox"/> Air condensation hood   |
|  |  | <input type="checkbox"/> Opposite side opening   |
|  |  | <input type="checkbox"/> Door lock with key      |

## TECHNICAL INSTALLATION DIAGRAM

Electricity supply  
cable inlet



Safety vent  
humidity



Chamber drain



Softened  
water inlet



Adjustable vent for  
excess humidity



**Important** - Drawing and  
dimensions refer to the  
standard version.  
They may change with the  
addition of accessories or  
options.

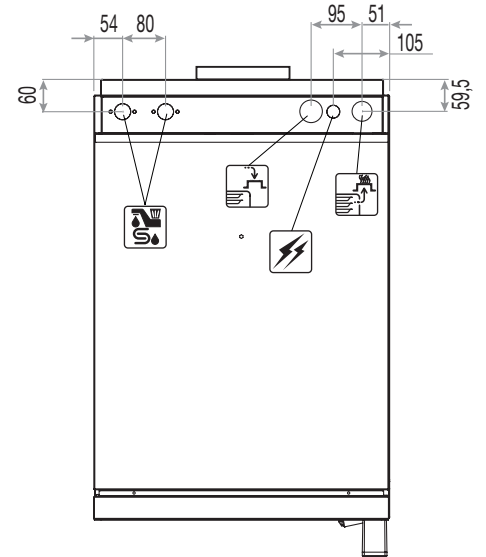
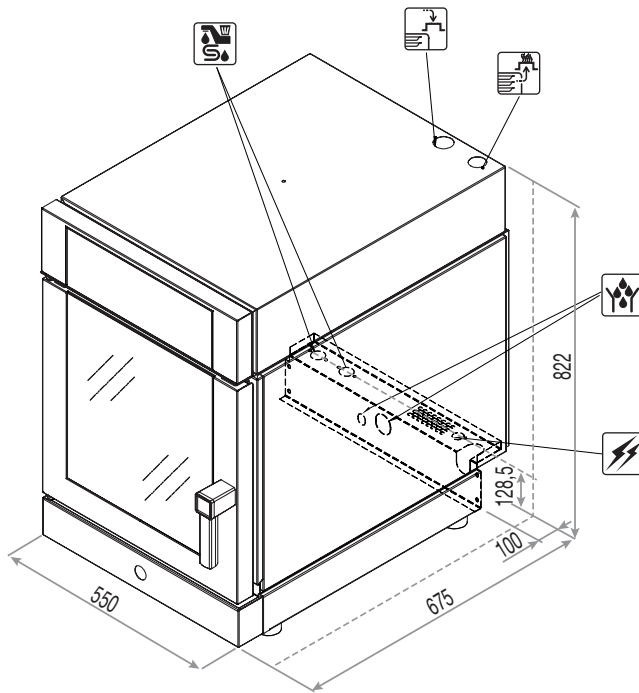

Overall dimensions  
(W x D x H) - mm

550 x 675 x 822h

Product max  
capacity [Kg]

10

Trays capacity

6 x GN 2/3

Total input  
[kW]

5,45 (400V)

Distance  
[mm]

64

Amps.  
[A]

7,9 (400V)

Power supply

380-415V 3N 50/60Hz

Water pressure  
[kPa]

150 ÷ 500

Working  
temperature [°C]

30 ÷ 280

Net weight  
[Kg]

65

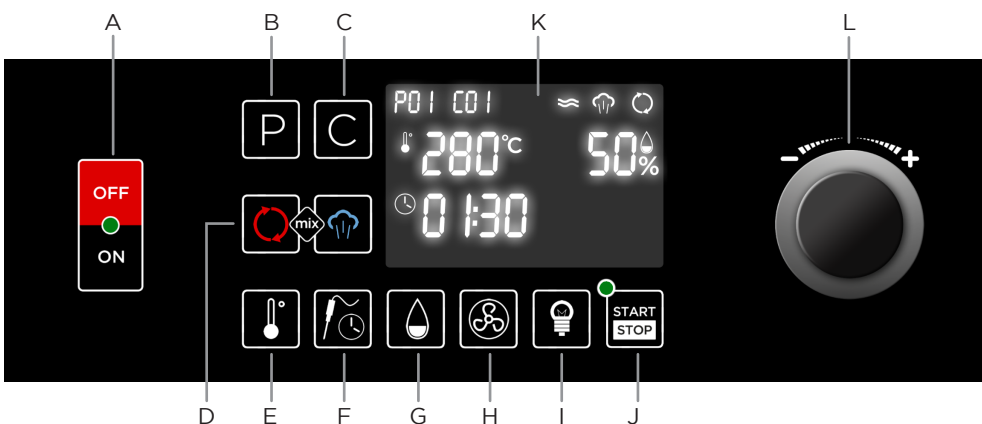

- A ON/OFF switch
- B Program and back key
- C Cycle key
- D Cooking mode key
- E Cavity temperature key
- F Probe / Time key
- G Humidity key
- H Fan speed key
- I Light key
- J START/STOP key
- K Digital display
- L Knob to set and enter key

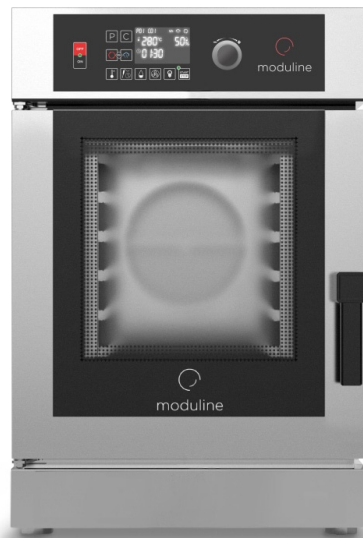

# COMBI GCE106DW

## Combi oven

### CONSTRUCTION FEATURES

- Tightness chamber with radiused corners
- Total thermic insulation with rock or glass wool
- Long lasting front seals made up of food grade of high heat resistance
- Removable side racks to facilitate cleaning
- Internal drain for easy cleaning
- Ventilated heating provided by high efficiency protected heating elements
- Snap-shut door
- Adjustable feet
- Easy access to facilitate maintenance and repair
- Double low-emission glass door with internal ventilation
- Openable inside glass of the door
- Condensation drip tray under the door and connected to the oven drainage system.





### FUNCTIONAL FEATURES

- Electronic control panel with digital display, keys and knob
- Simplified, user-friendly controls
- Periodic reversal of direction of rotation of the fan for better air distribution
- Automatic stopping of fans when the door is opened
- End-of-cycle buzzer
- Chamber with safety thermostat
- Operating temperature: from 30°C to 280°C in Convection mode, from 30°C to 280°C in Mixed Steam - Convection mode, from 30°C to 130°C in Direct Steam mode
- The cooking program can be divided into different phases
- Automatic humidity exhaust system after cooking
- Self-diagnosis system
- Steam condensation system
- Chamber cooling program
- IdealWarm function: the intelligent temperature decrease in the cavity at the end of the cooking cycle allows perfect warm holding
- Climachef system
- FlashDry instant dehumidification function of the chamber.
- PadLock: key lock system with password
- ProTime system allows you to set the date and the time you want the oven to preheat or start working.
- Glazed door plus lighting
- Removable GN1/1 tray racks
- EcoWash self-cleaning system

### OPTIONS & ACCESSORIES

- |  |  |  |
|--|--|--|
| <input type="checkbox"/> Supports                | <input type="checkbox"/> USB port                        | <input type="checkbox"/> Trays                 |
| <input type="checkbox"/> Multipoint core probe   | <input type="checkbox"/> SpeedGrade fan speed adjustment | <input type="checkbox"/> Sound silencer        |
| <input type="checkbox"/> Needle core probe, thin | <input type="checkbox"/> Water filter system             | <input type="checkbox"/> Air condensation hood |
| <input type="checkbox"/> External hand shower    | <input type="checkbox"/> Detergent/Rinsing agent         | <input type="checkbox"/> Opposite side opening |
| <input type="checkbox"/> Stacking kit            | <input type="checkbox"/> Grids                           | <input type="checkbox"/> Door lock with key    |

## TECHNICAL INSTALLATION DIAGRAM

- Electricity supply cable inlet 
- Safety vent humidity 
- Chamber drain 
- Softened water inlet 
- Adjustable vent for excess humidity 

**Important** - Drawing and dimensions refer to the standard version. They may change with the addition of accessories or options.

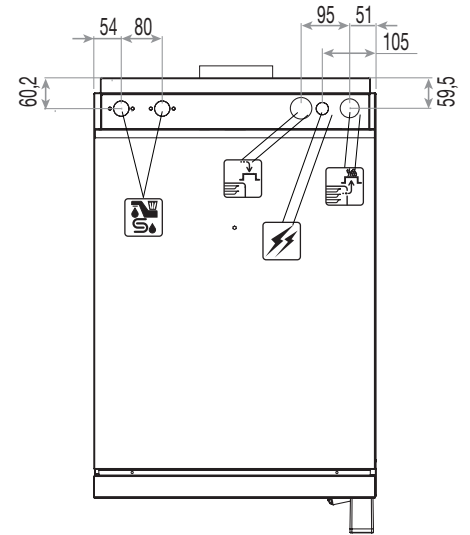
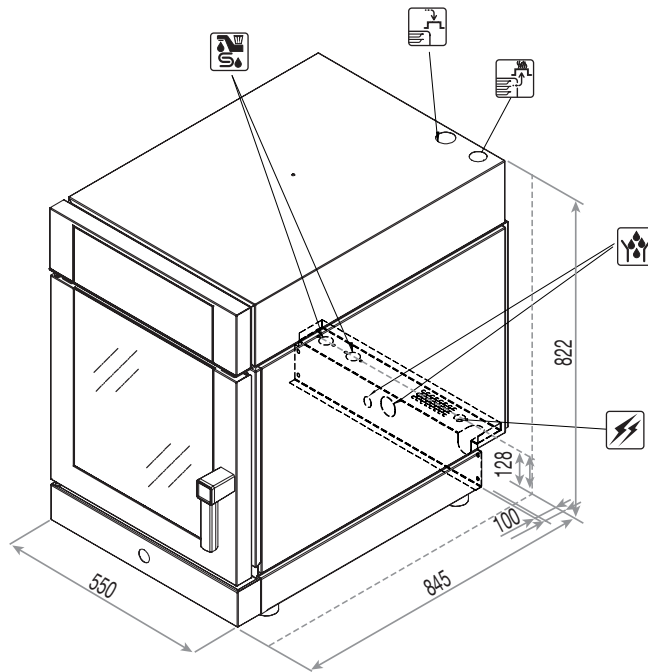

Overall dimensions (W x D x H) - mm

550 x 845 x 822h

Product max capacity [Kg]

15

Trays capacity

6 x GN 1/1

Total input [kW]

7,95 (400V)

Distance [mm]

64

Amps. [A]

11,5 (400V)

Power supply

380-415V 3N 50/60Hz

Water pressure [kPa]

150 ÷ 500

Working temperature [°C]

30 ÷ 280

Net weight [Kg]

90

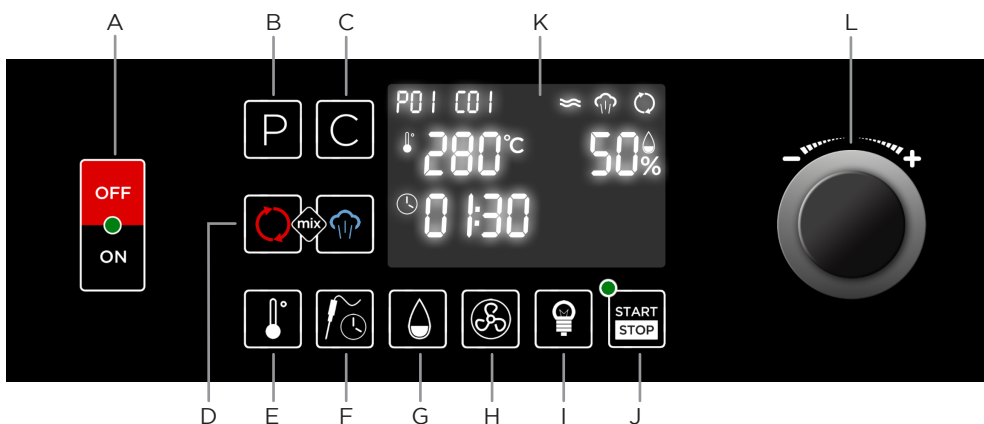

- A ON/OFF switch
- B Program and back key
- C Cycle key
- D Cooking mode key
- E Cavity temperature key
- F Probe / Time key
- G Humidity key
- H Fan speed key
- I Light key
- J START/STOP key
- K Digital display
- L Knob to set and enter key

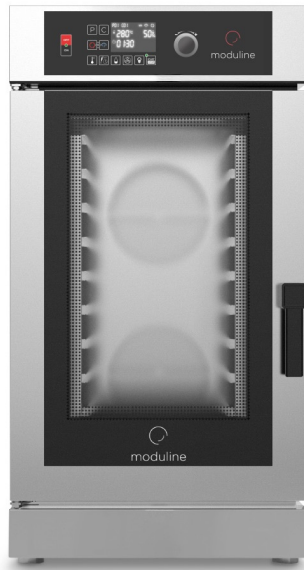

# COMBI GCE110DW

## Combi oven

### CONSTRUCTION FEATURES

- Tightness chamber with radiused corners
- Total thermic insulation with rock or glass wool
- Long lasting front seals made up of food grade of high heat resistance
- Removable side racks to facilitate cleaning
- Internal drain for easy cleaning
- Ventilated heating provided by high efficiency protected heating elements
- Snap-shut door
- Adjustable feet
- Easy access to facilitate maintenance and repair
- Double low-emission glass door with internal ventilation
- Openable inside glass of the door
- Condensation drip tray under the door and connected to the oven drainage system.





### FUNCTIONAL FEATURES

- Electronic control panel with digital display, keys and knob
- Simplified, user-friendly controls
- Periodic reversal of direction of rotation of the fan for better air distribution
- Automatic stopping of fans when the door is opened
- End-of-cycle buzzer
- Chamber with safety thermostat
- Operating temperature: from 30°C to 280°C in Convection mode, from 30°C to 280°C in Mixed Steam - Convection mode, from 30°C to 130°C in Direct Steam mode
- The cooking program can be divided into different phases
- Automatic humidity exhaust system after cooking
- Self-diagnosis system
- Steam condensation system
- Chamber cooling program
- IdealWarm function: the intelligent temperature decrease in the cavity at the end of the cooking cycle allows perfect warm holding
- Climachef system
- FlashDry instant dehumidification function of the chamber.
- PadLock: key lock system with password
- ProTime system allows you to set the date and the time you want the oven to preheat or start working.
- Glazed door plus lighting
- Removable GN1/1 tray racks
- EcoWash self-cleaning system

### OPTIONS & ACCESSORIES

- |  |  |  |
|--|--|--|
| <input type="checkbox"/> Supports                | <input type="checkbox"/> USB port                        | <input type="checkbox"/> Trays                 |
| <input type="checkbox"/> Multipoint core probe   | <input type="checkbox"/> SpeedGrade fan speed adjustment | <input type="checkbox"/> Sound silencer        |
| <input type="checkbox"/> Needle core probe, thin | <input type="checkbox"/> Water filter system             | <input type="checkbox"/> Air condensation hood |
| <input type="checkbox"/> External hand shower    | <input type="checkbox"/> Detergent/Rinsing agent         | <input type="checkbox"/> Opposite side opening |
|  | <input type="checkbox"/> Grids                           | <input type="checkbox"/> Door lock with key    |

## TECHNICAL INSTALLATION DIAGRAM

- Electricity supply cable inlet 
- Safety vent humidity 
- Chamber drain 
- Softened water inlet 
- Adjustable vent for excess humidity 

**Important** - Drawing and dimensions refer to the standard version. They may change with the addition of accessories or options.

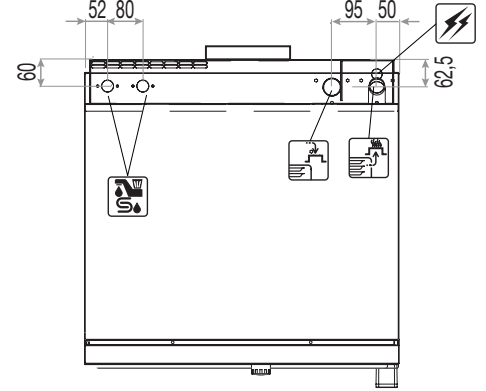
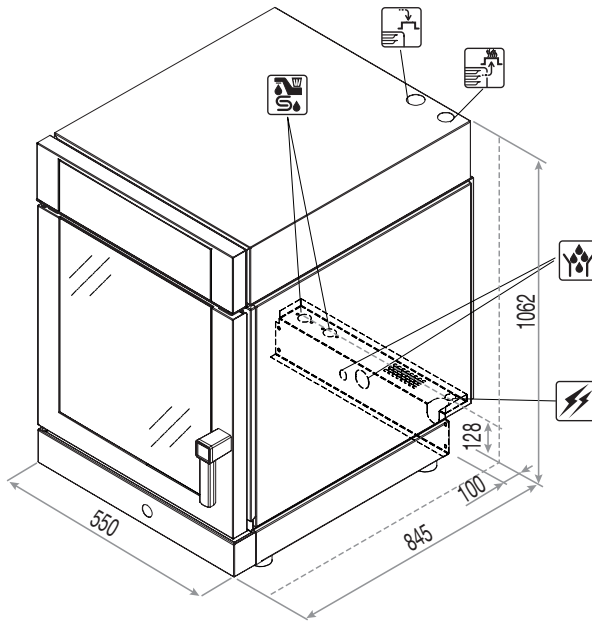

Overall dimensions (W x D x H) - mm	550 x 845 x 1062h	Product max capacity [Kg]	24
Trays capacity	10 x GN 1/1	Total input [kW]	12,65 (400V)
Distance [mm]	64	Amps. [A]	18,3 (400V)
Power supply	380-415V 3N 50/60Hz	Water pressure [kPa]	150 ÷ 500
Working temperature [°C]	30 ÷ 280	Net weight [Kg]	100

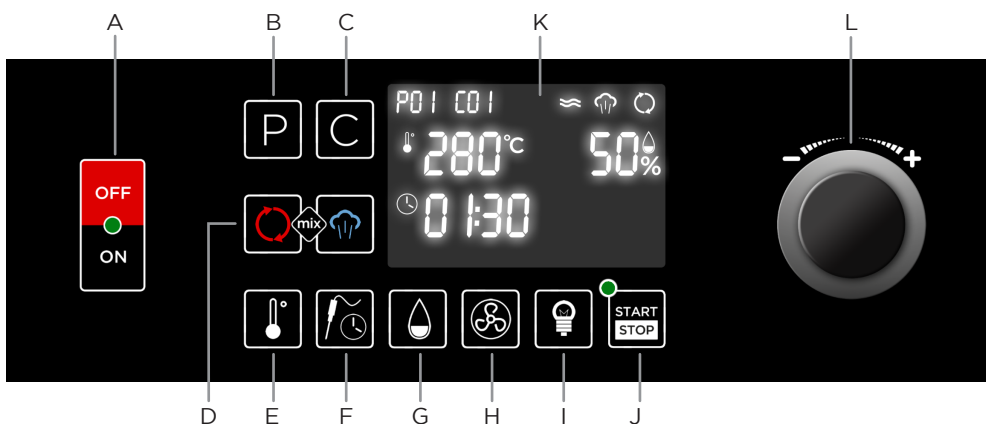

- A ON/OFF switch
- B Program and back key
- C Cycle key
- D Cooking mode key
- E Cavity temperature key
- F Probe / Time key
- G Humidity key
- H Fan speed key
- I Light key
- J START/STOP key
- K Digital display
- L Knob to set and enter key



# COMBI GCE061DW

## Combi oven

### CONSTRUCTION FEATURES

- Tightness chamber with radiused corners
- Total thermic insulation with rock or glass wool
- Long lasting front seals made up of food grade of high heat resistance
- Removable side racks to facilitate cleaning
- Internal drain for easy cleaning
- Ventilated heating provided by high efficiency protected heating elements
- Snap-shut door
- Adjustable feet
- Easy access to facilitate maintenance and repair
- Double low-emission glass door with internal ventilation
- Openable inside glass of the door
- Condensation drip tray under the door and connected to the oven drainage system.





### FUNCTIONAL FEATURES

- Electronic control panel with digital display, keys and knob
- Simplified, user-friendly controls
- Periodic reversal of direction of rotation of the fan for better air distribution
- Automatic stopping of fans when the door is opened
- End-of-cycle buzzer
- Chamber with safety thermostat
- Operating temperature: from 30°C to 280°C in Convection mode, from 30°C to 280°C in Mixed Steam - Convection mode, from 30°C to 130°C in Direct Steam mode
- The cooking program can be divided into different phases
- Automatic humidity exhaust system after cooking
- Self-diagnosis system
- Steam condensation system
- Chamber cooling program
- IdealWarm function: the intelligent temperature decrease in the cavity at the end of the cooking cycle allows perfect warm holding
- Climachef system
- FlashDry instant dehumidification function of the chamber.
- PadLock: key lock system with password
- ProTime system allows you to set the date and the time you want the oven to preheat or start working.
- Glazed door plus lighting
- Removable GN1/1 tray racks
- EcoWash self-cleaning system

### OPTIONS & ACCESSORIES

- |  |  |  |
|--|--|--|
| <input type="checkbox"/> Supports                | <input type="checkbox"/> Wall brackets kit               | <input type="checkbox"/> Detergent/Rinsing agent |
| <input type="checkbox"/> Multipoint core probe   | <input type="checkbox"/> Stacking kit                    | <input type="checkbox"/> Grids                   |
| <input type="checkbox"/> Needle core probe, thin | <input type="checkbox"/> USB port                        | <input type="checkbox"/> Trays                   |
| <input type="checkbox"/> External hand shower    | <input type="checkbox"/> SpeedGrade fan speed adjustment | <input type="checkbox"/> Sound silencer          |
| <input type="checkbox"/> Built-in sliding kit    | <input type="checkbox"/> Water filter system             | <input type="checkbox"/> Air condensation hood   |
|  |  | <input type="checkbox"/> Opposite side opening   |
|  |  | <input type="checkbox"/> Side racks 600x400      |
|  |  | <input type="checkbox"/> Door lock with key      |

## TECHNICAL INSTALLATION DIAGRAM

- Electricity supply cable inlet 
- Safety vent humidity 
- Chamber drain 
- Softened water inlet 
- Adjustable vent for excess humidity 

**Important** - Drawing and dimensions refer to the standard version. They may change with the addition of accessories or options.

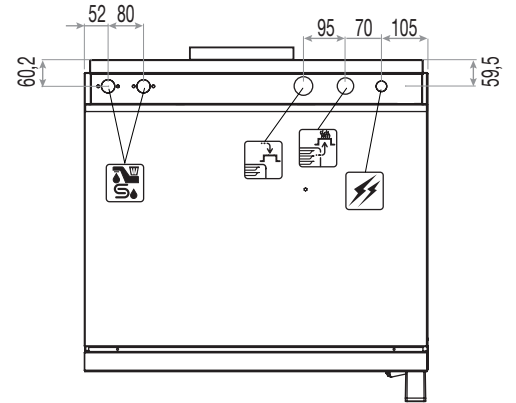
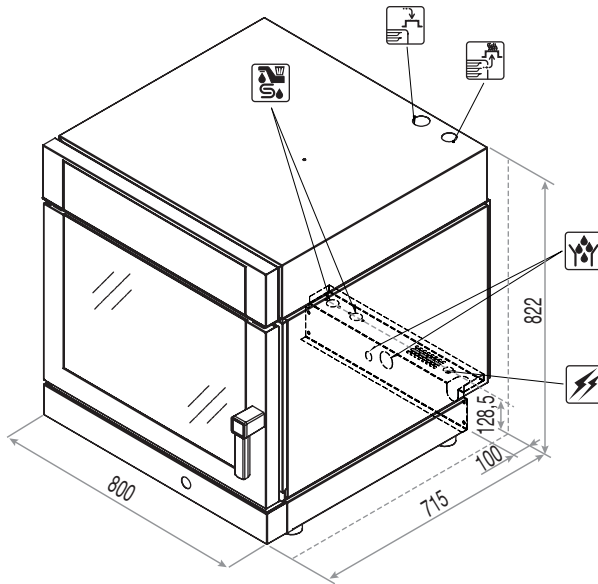

Overall dimensions (W x D x H) - mm

800 x 715 x 822h

Product max capacity [Kg]

15

Trays capacity

6 x GN 1/1 or 600x400

Total input [kW]

7,95 (400V)

Distance [mm]

64

Amps. [A]

11,5 (400V)

Power supply

380-415V 3N 50/60Hz

Water pressure [kPa]

150 ÷ 500

Working temperature [°C]

30 ÷ 280

Net weight [Kg]

90

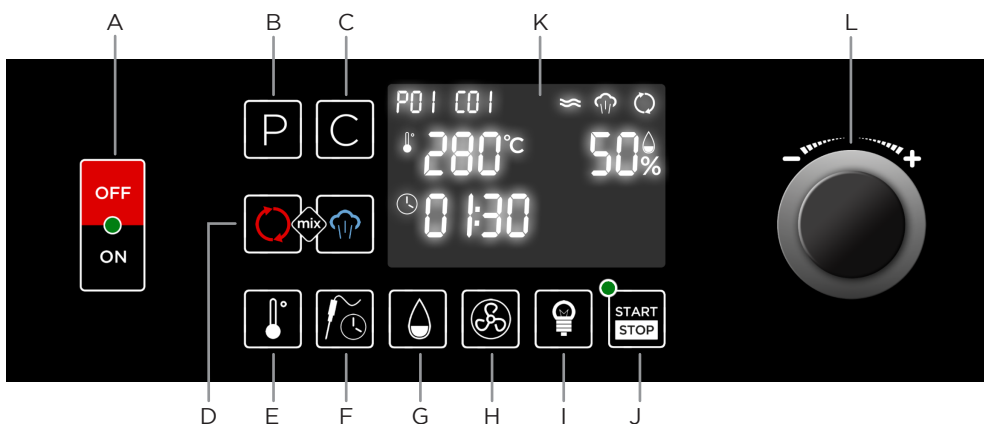

- A ON/OFF switch
- B Program and back key
- C Cycle key
- D Cooking mode key
- E Cavity temperature key
- F Probe / Time key
- G Humidity key
- H Fan speed key
- I Light key
- J START/STOP key
- K Digital display
- L Knob to set and enter key



# COMBI GCE101DW

## Combi oven

### CONSTRUCTION FEATURES

- Tightness chamber with radiused corners
- Total thermic insulation with rock or glass wool
- Long lasting front seals made up of food grade of high heat resistance
- Removable side racks to facilitate cleaning
- Internal drain for easy cleaning
- Ventilated heating provided by high efficiency protected heating elements
- Snap-shut door
- Adjustable feet
- Easy access to facilitate maintenance and repair
- Double low-emission glass door with internal ventilation
- Openable inside glass of the door
- Condensation drip tray under the door and connected to the oven drainage system.





### FUNCTIONAL FEATURES

- Electronic control panel with digital display, keys and knob
- Simplified, user-friendly controls
- Periodic reversal of direction of rotation of the fan for better air distribution
- Automatic stopping of fans when the door is opened
- End-of-cycle buzzer
- Chamber with safety thermostat
- Operating temperature: from 30°C to 280°C in Convection mode, from 30°C to 280°C in Mixed Steam - Convection mode, from 30°C to 130°C in Direct Steam mode
- The cooking program can be divided into different phases
- Automatic humidity exhaust system after cooking
- Self-diagnosis system
- Steam condensation system
- Chamber cooling program
- IdealWarm function: the intelligent temperature decrease in the cavity at the end of the cooking cycle allows perfect warm holding
- Climachef system
- FlashDry instant dehumidification function of the chamber.
- PadLock: key lock system with password
- ProTime system allows you to set the date and the time you want the oven to preheat or start working.
- Glazed door plus lighting
- Removable GN1/1 tray racks
- EcoWash self-cleaning system

### OPTIONS & ACCESSORIES

- |  |  |  |
|--|--|--|
| <input type="checkbox"/> Supports                | <input type="checkbox"/> USB port                        | <input type="checkbox"/> Trays                 |
| <input type="checkbox"/> Multipoint core probe   | <input type="checkbox"/> SpeedGrade fan speed adjustment | <input type="checkbox"/> Sound silencer        |
| <input type="checkbox"/> Needle core probe, thin | <input type="checkbox"/> Water filter system             | <input type="checkbox"/> Air condensation hood |
| <input type="checkbox"/> External hand shower    | <input type="checkbox"/> Detergent/Rinsing agent         | <input type="checkbox"/> Opposite side opening |
|  | <input type="checkbox"/> Grids                           | <input type="checkbox"/> Side racks 600x400    |
|  |  | <input type="checkbox"/> Door lock with key    |

## TECHNICAL INSTALLATION DIAGRAM

- Electricity supply cable inlet 
- Safety vent humidity 
- Chamber drain 
- Softened water inlet 
- Adjustable vent for excess humidity 

**Important** - Drawing and dimensions refer to the standard version. They may change with the addition of accessories or options.

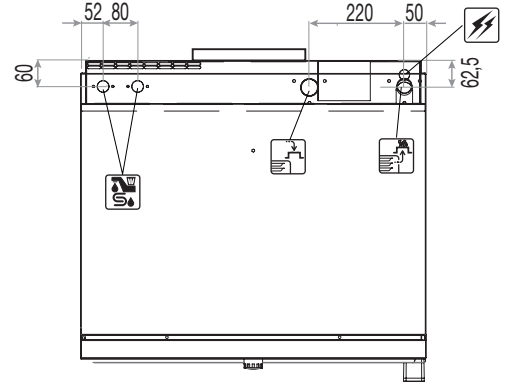
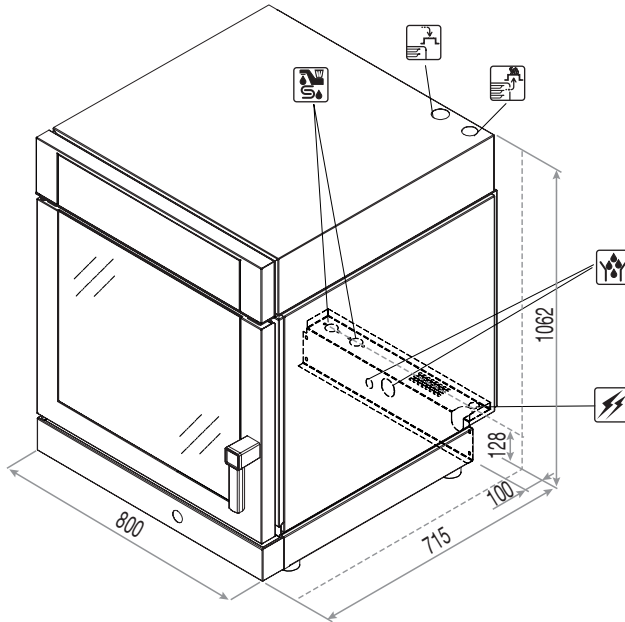

**Overall dimensions (W x D x H) - mm**

800 x 715 x 1062h

**Product max capacity [Kg]**

24

**Trays capacity**

10 x GN 1/1 or 600x400

**Total input [kW]**

15,65 (400V)

**Distance [mm]**

64

**Amps. [A]**

22,7 (400V)

**Power supply**

380-415V 3N 50/60Hz

**Water pressure [kPa]**

150 ÷ 500

**Working temperature [°C]**

30 ÷ 280

**Net weight [Kg]**

100

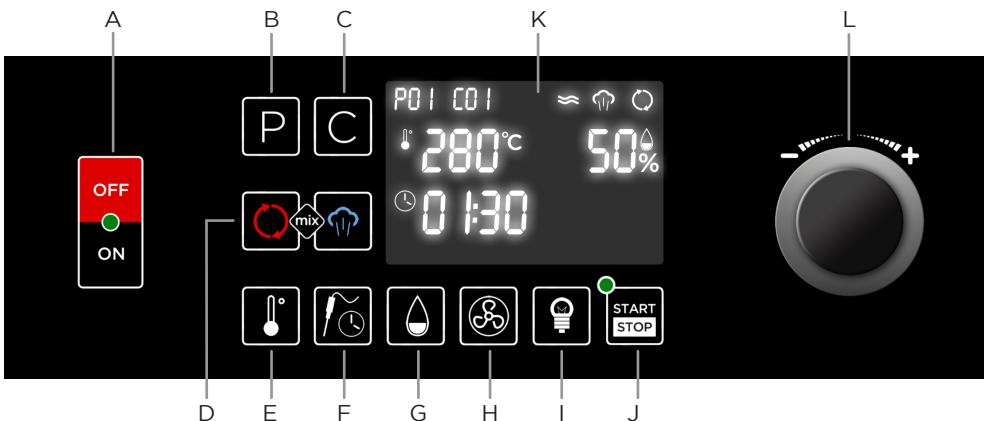

- A ON/OFF switch
- B Program and back key
- C Cycle key
- D Cooking mode key
- E Cavity temperature key
- F Probe / Time key
- G Humidity key
- H Fan speed key
- I Light key
- J START/STOP key
- K Digital display
- L Knob to set and enter key

## По вопросам продаж и поддержки обращайтесь:

Алматы (727)345-47-04  
Ангарск (3955)60-70-56  
Архангельск (8182)63-90-72  
Астрахань (8512)99-46-04  
Барнаул (3852)73-04-60  
Белгород (4722)40-23-64  
Благовещенск (4162)22-76-07  
Брянск (4832)59-03-52  
Владивосток (423)249-28-31  
Владикавказ (8672)28-90-48  
Владимир (4922)49-43-18  
Волгоград (844)278-03-48  
Вологда (8172)26-41-59  
Воронеж (473)204-51-73  
Екатеринбург (343)384-55-89

Иваново (4932)77-34-06  
Ижевск (3412)26-03-58  
Иркутск (395)279-98-46  
Казань (843)206-01-48  
Калининград (4012)72-03-81  
Калуга (4842)92-23-67  
Кемерово (3842)65-04-62  
Киров (8332)68-02-04  
Коломна (4966)23-41-49  
Кострома (4942)77-07-48  
Краснодар (861)203-40-90  
Красноярск (391)204-63-61  
Курск (4712)77-13-04  
Курган (3522)50-90-47  
Липецк (4742)52-20-81

Магнитогорск (3519)55-03-13  
Москва (495)268-04-70  
Мурманск (8152)59-64-93  
Набережные Челны (8552)20-53-41  
Нижний Новгород (831)429-08-12  
Новокузнецк (3843)20-46-81  
Ноябрьск (3496)41-32-12  
Новосибирск (383)227-86-73  
Омск (3812)21-46-40  
Орел (4862)44-53-42  
Оренбург (3532)37-68-04  
Пенза (8412)22-31-16  
Петрозаводск (8142)55-98-37  
Псков (8112)59-10-37  
Пермь (342)205-81-47

Ростов-на-Дону (863)308-18-15  
Рязань (4912)46-61-64  
Самара (846)206-03-16  
Санкт-Петербург (812)309-46-40  
Саратов (845)249-38-78  
Севастополь (8692)22-31-93  
Саранск (8342)22-96-24  
Симферополь (3652)67-13-56  
Смоленск (4812)29-41-54  
Сочи (862)225-72-31  
Ставрополь (8652)20-65-13  
Сургут (3462)77-98-35  
Сыктывкар (8212)25-95-17  
Тамбов (4752)50-40-97  
Тверь (4822)63-31-35

Тольятти (8482)63-91-07  
Томск (3822)98-41-53  
Тула (4872)33-79-87  
Тюмень (3452)66-21-18  
Ульяновск (8422)24-23-59  
Улан-Удэ (3012)59-97-51  
Уфа (347)229-48-12  
Хабаровск (4212)92-98-04  
Чебоксары (8352)28-53-07  
Челябинск (351)202-03-61  
Череповец (8202)49-02-64  
Чита (3022)38-34-83  
Якутск (4112)23-90-97  
Ярославль (4852)69-52-93

**Россия** +7(495)268-04-70

**Казахстан** +7(727)345-47-04

**Беларусь** +(375)257-127-884

**Узбекистан** +998(71)205-18-59

**Киргизия** +996(312)96-26-47

эл.почта: [meo@nt-rt.ru](mailto:meo@nt-rt.ru) || сайт: <https://module.nt-rt.ru/>