

Регенерационные печи GRE версия С

Технические характеристики

По вопросам продаж и поддержки обращайтесь:

Алматы (727)345-47-04
Ангарск (3955)60-70-56
Архангельск (8182)63-90-72
Астрахань (8512)99-46-04
Барнаул (3852)73-04-60
Белгород (4722)40-23-64
Благовещенск (4162)22-76-07
Брянск (4832)59-03-52
Владивосток (423)249-28-31
Владикавказ (8672)28-90-48
Владимир (4922)49-43-18
Волгоград (844)278-03-48
Вологда (8172)26-41-59
Воронеж (473)204-51-73
Екатеринбург (343)384-55-89

Иваново (4932)77-34-06
Ижевск (3412)26-03-58
Иркутск (395)279-98-46
Казань (843)206-01-48
Калининград (4012)72-03-81
Калуга (4842)92-23-67
Кемерово (3842)65-04-62
Киров (8332)68-02-04
Коломна (4966)23-41-49
Кострома (4942)77-07-48
Краснодар (861)203-40-90
Красноярск (391)204-63-61
Курск (4712)77-13-04
Курган (3522)50-90-47
Липецк (4742)52-20-81

Магнитогорск (3519)55-03-13
Москва (495)268-04-70
Мурманск (8152)59-64-93
Набережные Челны (8552)20-53-41
Нижний Новгород (831)429-08-12
Новокузнецк (3843)20-46-81
Ноябрьск (3496)41-32-12
Новосибирск (383)227-86-73
Омск (3812)21-46-40
Орел (4862)44-53-42
Оренбург (3532)37-68-04
Пенза (8412)22-31-16
Петрозаводск (8142)55-98-37
Псков (8112)59-10-37
Пермь (342)205-81-47

Ростов-на-Дону (863)308-18-15
Рязань (4912)46-61-64
Самара (846)206-03-16
Санкт-Петербург (812)309-46-40
Саратов (845)249-38-78
Севастополь (8692)22-31-93
Саранск (8342)22-96-24
Симферополь (3652)67-13-56
Смоленск (4812)29-41-54
Сочи (862)225-72-31
Ставрополь (8652)20-65-13
Сургут (3462)77-98-35
Сыктывкар (8212)25-95-17
Тамбов (4752)50-40-97
Тверь (4822)63-31-35

Тольятти (8482)63-91-07
Томск (3822)98-41-53
Тула (4872)33-79-87
Тюмень (3452)66-21-18
Ульяновск (8422)24-23-59
Улан-Удэ (3012)59-97-51
Уфа (347)229-48-12
Хабаровск (4212)92-98-04
Чебоксары (8352)28-53-07
Челябинск (351)202-03-61
Череповец (8202)49-02-64
Чита (3022)38-34-83
Якутск (4112)23-90-97
Ярославль (4852)69-52-93

Россия +7(495)268-04-70

Казахстан +7(727)345-47-04

Беларусь +(375)257-127-884

Узбекистан +998(71)205-18-59

Киргизия +996(312)96-26-47

эл.почта: meo@nt-rt.ru || сайт: <https://module.nt-rt.ru/>



REThERM GRE060C

Regeneration oven
to reheat refrigerated
food (+3°C)

CONSTRUCTION FEATURES

- Tightness chamber with radiused corners
- Total thermic insulation with rock or glass wool
- Long lasting front seals made up of food grade of high heat resistance
- Removable side racks to facilitate cleaning
- Internal drain for easy cleaning
- Ventilated heating provided by high efficiency protected heating elements
- Snap-shut door
- Adjustable feet
- Easy access to facilitate maintenance and repair
- Double low-emission glass door with internal ventilation
- Condensation drip tray under the door and connected to the oven drainage system.

FUNCTIONAL FEATURES

- Electromechanical controls: main switch, lights switch, timer, moisture, temperature
- Simplified, user-friendly controls
- Periodic reversal of direction of rotation of the fan for better air distribution
- Automatic stopping of fans when the door is opened
- End-of-cycle buzzer
- Chamber with safety thermostat
- Operating temperature 30°C ÷ 160°C
- Glazed door plus lighting
- Removable GN2/3 tray racks

OPTIONS & ACCESSORIES

- Supports
- Openable inside glass of the door
- Wall brackets kit
- Water filter system
- Grids
- Trays
- Opposite side opening
- Door lock with key

TECHNICAL INSTALLATION DIAGRAM

Electricity supply
cable inlet



Vent for excess
humidity



Chamber drain



Softened
water inlet



Important - Drawing and
dimensions refer to the
standard version.
They may change with the
addition of accessories or
options.

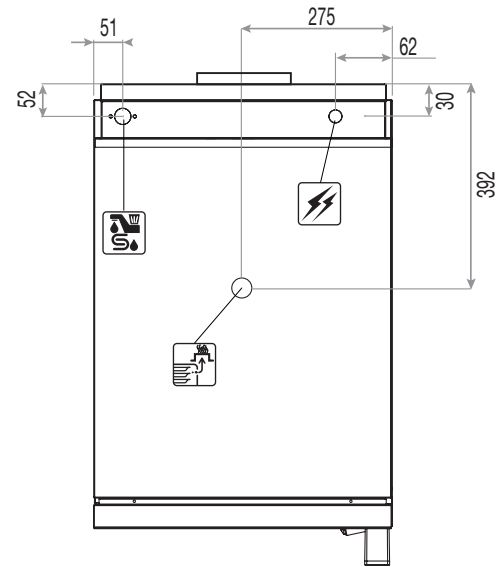
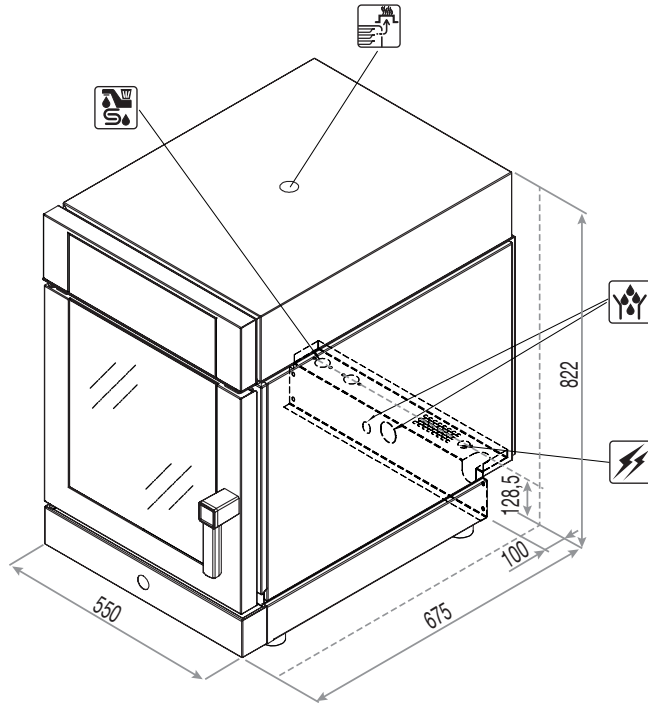

Overall dimensions
(W x D x H) - mm

550 x 675 x 822 h

Trays capacity

6 x GN 2/3

Plates capacity

6 Ø 200-320

Distance
[mm]

64

Power supply

AC 220-240V 50/60Hz

**Working
temperature [°C]**

30 ÷ 160

**Product max
capacity [Kg]**

10

Total input
[kW]

3,45 (230V)

Amps.
[A]

15 (230V)

Water pressure
[kPa]

150 ÷ 500

Net weight
[Kg]

65

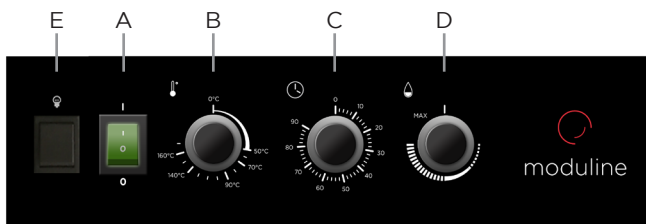

- A ON/OFF switch
- B Cavity temperature knob
- C Time setting knob
- D Cavity humidity control knob
- E Chamber light button



REThERM GRE061C

Regeneration oven
to reheat refrigerated
food (+3°C)

CONSTRUCTION FEATURES

- Tightness chamber with radiused corners
- Total thermic insulation with rock or glass wool
- Long lasting front seals made up of food grade of high heat resistance
- Removable side racks to facilitate cleaning
- Internal drain for easy cleaning
- Ventilated heating provided by high efficiency protected heating elements
- Snap-shut door
- Adjustable feet
- Easy access to facilitate maintenance and repair
- Double low-emission glass door with internal ventilation
- Condensation drip tray under the door and connected to the oven drainage system.





FUNCTIONAL FEATURES

- Electromechanical controls: main switch, lights switch, timer, moisture, temperature
- Simplified, user-friendly controls
- Periodic reversal of direction of rotation of the fan for better air distribution
- Automatic stopping of fans when the door is opened
- End-of-cycle buzzer
- Chamber with safety thermostat
- Operating temperature 30°C ÷ 160°C
- Glazed door plus lighting
- Removable GN1/1 tray racks

OPTIONS & ACCESSORIES

- Supports
- Openable inside glass of the door
- Wall brackets kit
- Water filter system
- Grids
- Trays
- Side racks 600x400
- Opposite side opening
- Door lock with key

TECHNICAL INSTALLATION DIAGRAM

- Electricity supply cable inlet 
- Vent for excess humidity 
- Chamber drain 
- Softened water inlet 

Important - Drawing and dimensions refer to the standard version. They may change with the addition of accessories or options.

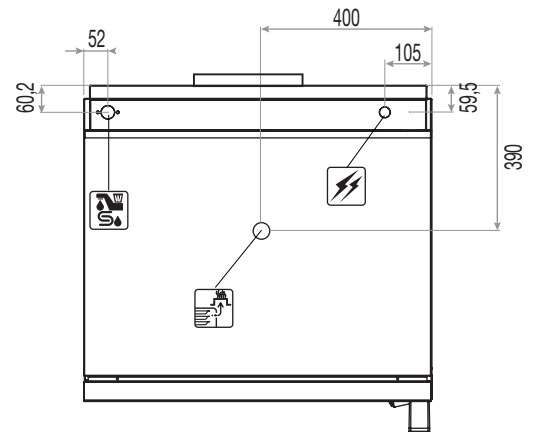
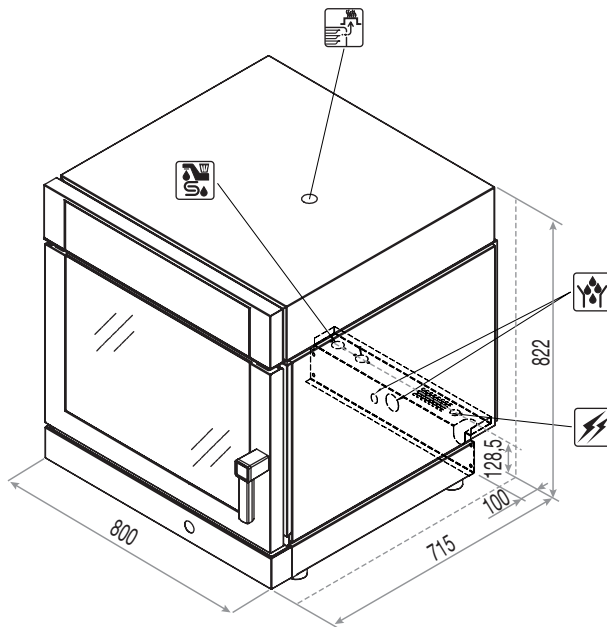

Overall dimensions (W x D x H) - mm	800 x 690 x 822 h	Product max capacity [Kg]	15
Trays capacity	6 x GN 1/1 or 600x400	Total input [kW]	3,45 (230V)
Plates capacity (side racks GN1/1)	12 Ø 200-260 6 Ø 270-320	Amps. [A]	15 (230V)
Distance [mm]	64	Water pressure [kPa]	150 ÷ 500
Power supply	AC 220-240V 50/60Hz	Net weight [Kg]	90
Working temperature [°C]	30 ÷ 160		

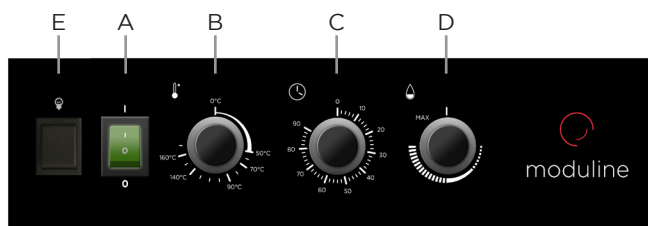

- A ON/OFF switch
- B Cavity temperature knob
- C Time setting knob
- D Cavity humidity control knob
- E Chamber light button



REThERM GRE106C

Regeneration oven
to reheat refrigerated
food (+3°C)

CONSTRUCTION FEATURES

- Tightness chamber with radiused corners
- Total thermic insulation with rock or glass wool
- Long lasting front seals made up of food grade of high heat resistance
- Removable side racks to facilitate cleaning
- Internal drain for easy cleaning
- Ventilated heating provided by high efficiency protected heating elements
- Snap-shut door
- Adjustable feet
- Easy access to facilitate maintenance and repair
- Double low-emission glass door with internal ventilation
- Condensation drip tray under the door and connected to the oven drainage system.

FUNCTIONAL FEATURES

- Electromechanical controls: main switch, lights switch, timer, moisture, temperature
- Simplified, user-friendly controls
- Periodic reversal of direction of rotation of the fan for better air distribution
- Automatic stopping of fans when the door is opened
- End-of-cycle buzzer
- Chamber with safety thermostat
- Operating temperature 30°C ÷ 160°C
- Glazed door plus lighting
- Removable GN1/1 tray racks

OPTIONS & ACCESSORIES

- Supports
- Openable inside glass of the door
- Water filter system
- Grids
- Trays
- Opposite side opening
- Door lock with key

TECHNICAL INSTALLATION DIAGRAM

Electricity supply
cable inlet



Vent for excess
humidity



Chamber drain



Softened
water inlet



Important - Drawing and
dimensions refer to the
standard version.
They may change with the
addition of accessories or
options.

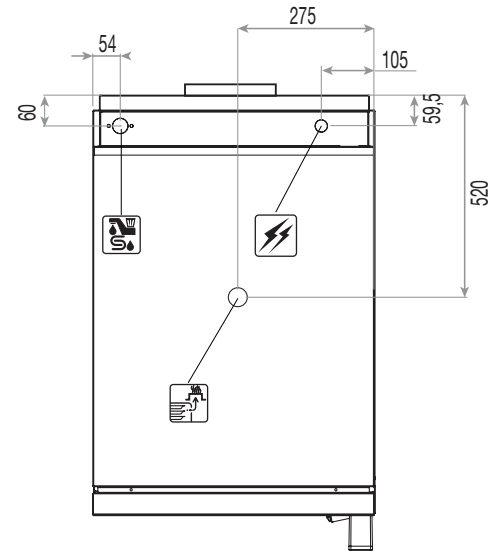
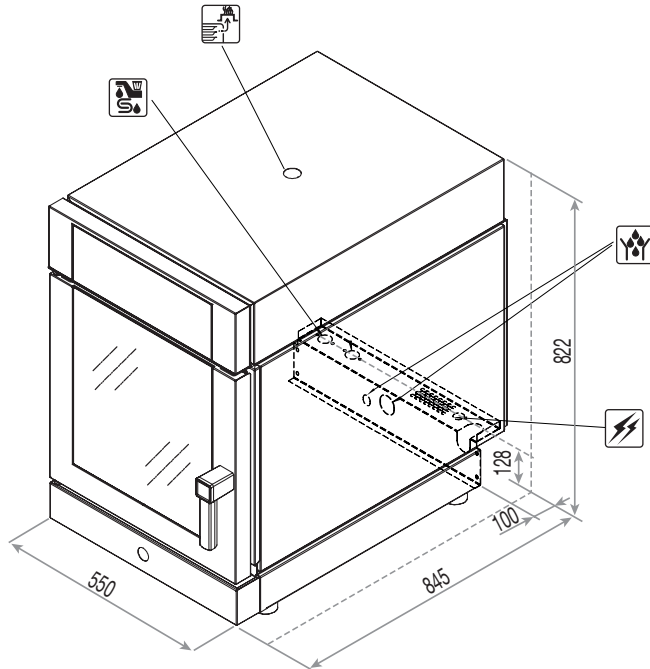

Overall dimensions
(W x D x H) - mm

550 x 845 x 822 h

Trays capacity

6 x GN 1/1

Plates capacity

12 Ø 200-260
6 Ø 270-320

Distance
[mm]

64

Power supply

AC 220-240V 50/60Hz

Working
temperature [°C]

30 ÷ 160

Product max
capacity [Kg]

15

Total input
[kW]

3,45 (230V)

Amps.
[A]

15 (230V)

Water pressure
[kPa]

150 ÷ 500

Net weight
[Kg]

90

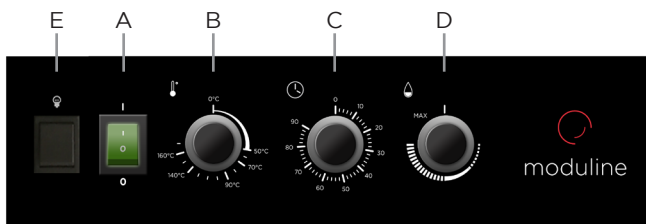

- A ON/OFF switch
- B Cavity temperature knob
- C Time setting knob
- D Cavity humidity control knob
- E Chamber light button

По вопросам продаж и поддержки обращайтесь:

Алматы (727)345-47-04
Ангарск (3955)60-70-56
Архангельск (8182)63-90-72
Астрахань (8512)99-46-04
Барнаул (3852)73-04-60
Белгород (4722)40-23-64
Благовещенск (4162)22-76-07
Брянск (4832)59-03-52
Владивосток (423)249-28-31
Владикавказ (8672)28-90-48
Владимир (4922)49-43-18
Волгоград (844)278-03-48
Вологда (8172)26-41-59
Воронеж (473)204-51-73
Екатеринбург (343)384-55-89

Иваново (4932)77-34-06
Ижевск (3412)26-03-58
Иркутск (395)279-98-46
Казань (843)206-01-48
Калининград (4012)72-03-81
Калуга (4842)92-23-67
Кемерово (3842)65-04-62
Киров (8332)68-02-04
Коломна (4966)23-41-49
Кострома (4942)77-07-48
Краснодар (861)203-40-90
Красноярск (391)204-63-61
Курск (4712)77-13-04
Курган (3522)50-90-47
Липецк (4742)52-20-81

Магнитогорск (3519)55-03-13
Москва (495)268-04-70
Мурманск (8152)59-64-93
Набережные Челны (8552)20-53-41
Нижний Новгород (831)429-08-12
Новокузнецк (3843)20-46-81
Ноябрьск (3496)41-32-12
Новосибирск (383)227-86-73
Омск (3812)21-46-40
Орел (4862)44-53-42
Оренбург (3532)37-68-04
Пенза (8412)22-31-16
Петрозаводск (8142)55-98-37
Псков (8112)59-10-37
Пермь (342)205-81-47

Ростов-на-Дону (863)308-18-15
Рязань (4912)46-61-64
Самара (846)206-03-16
Санкт-Петербург (812)309-46-40
Саратов (845)249-38-78
Севастополь (8692)22-31-93
Саранск (8342)22-96-24
Симферополь (3652)67-13-56
Смоленск (4812)29-41-54
Сочи (862)225-72-31
Ставрополь (8652)20-65-13
Сургут (3462)77-98-35
Сыктывкар (8212)25-95-17
Тамбов (4752)50-40-97
Тверь (4822)63-31-35

Тольятти (8482)63-91-07
Томск (3822)98-41-53
Тула (4872)33-79-87
Тюмень (3452)66-21-18
Ульяновск (8422)24-23-59
Улан-Удэ (3012)59-97-51
Уфа (347)229-48-12
Хабаровск (4212)92-98-04
Чебоксары (8352)28-53-07
Челябинск (351)202-03-61
Череповец (8202)49-02-64
Чита (3022)38-34-83
Якутск (4112)23-90-97
Ярославль (4852)69-52-93

Россия +7(495)268-04-70

Казахстан +7(727)345-47-04

Беларусь +(375)257-127-884

Узбекистан +998(71)205-18-59

Киргизия +996(312)96-26-47

эл.почта: meo@nt-rt.ru || сайт: <https://module.nt-rt.ru/>