

Регенерационные печи RRT версия E, D, C

Технические характеристики

По вопросам продаж и поддержки обращайтесь:

Алматы (727)345-47-04
Ангарск (3955)60-70-56
Архангельск (8182)63-90-72
Астрахань (8512)99-46-04
Барнаул (3852)73-04-60
Белгород (4722)40-23-64
Благовещенск (4162)22-76-07
Брянск (4832)59-03-52
Владивосток (423)249-28-31
Владикавказ (8672)28-90-48
Владимир (4922)49-43-18
Волгоград (844)278-03-48
Вологда (8172)26-41-59
Воронеж (473)204-51-73
Екатеринбург (343)384-55-89

Иваново (4932)77-34-06
Ижевск (3412)26-03-58
Иркутск (395)279-98-46
Казань (843)206-01-48
Калининград (4012)72-03-81
Калуга (4842)92-23-67
Кемерово (3842)65-04-62
Киров (8332)68-02-04
Коломна (4966)23-41-49
Кострома (4942)77-07-48
Краснодар (861)203-40-90
Красноярск (391)204-63-61
Курск (4712)77-13-04
Курган (3522)50-90-47
Липецк (4742)52-20-81

Магнитогорск (3519)55-03-13
Москва (495)268-04-70
Мурманск (8152)59-64-93
Набережные Челны (8552)20-53-41
Нижний Новгород (831)429-08-12
Новокузнецк (3843)20-46-81
Ноябрьск (3496)41-32-12
Новосибирск (383)227-86-73
Омск (3812)21-46-40
Орел (4862)44-53-42
Оренбург (3532)37-68-04
Пенза (8412)22-31-16
Петрозаводск (8142)55-98-37
Псков (8112)59-10-37
Пермь (342)205-81-47

Ростов-на-Дону (863)308-18-15
Рязань (4912)46-61-64
Самара (846)206-03-16
Санкт-Петербург (812)309-46-40
Саратов (845)249-38-78
Севастополь (8692)22-31-93
Саранск (8342)22-96-24
Симферополь (3652)67-13-56
Смоленск (4812)29-41-54
Сочи (862)225-72-31
Ставрополь (8652)20-65-13
Сургут (3462)77-98-35
Сыктывкар (8212)25-95-17
Тамбов (4752)50-40-97
Тверь (4822)63-31-35

Тольятти (8482)63-91-07
Томск (3822)98-41-53
Тула (4872)33-79-87
Тюмень (3452)66-21-18
Ульяновск (8422)24-23-59
Улан-Удэ (3012)59-97-51
Уфа (347)229-48-12
Хабаровск (4212)92-98-04
Чебоксары (8352)28-53-07
Челябинск (351)202-03-61
Череповец (8202)49-02-64
Чита (3022)38-34-83
Якутск (4112)23-90-97
Ярославль (4852)69-52-93

Россия +7(495)268-04-70

Казахстан +7(727)345-47-04

Беларусь +(375)257-127-884

Узбекистан +998(71)205-18-59

Киргизия +996(312)96-26-47

эл.почта: meo@nt-rt.ru || сайт: <https://module.nt-rt.ru/>



RE THERM RRT051C/D/E

Regeneration oven
to reheat refrigerated
food (+3°C)

CONSTRUCTION FEATURES

- Tightness chamber with radiused corners
- All-around rubber bumpers
- Total thermic insulation with rock or glass wool
- Long lasting front seal, made up of food-grade and high-heat resistant silicone
- Removable side racks to facilitate cleaning
- Internal drain for easy cleaning
- Ventilated heating provided by high efficiency protected heating elements
- Snap-shut door
- Mounted on four 125mm diameter castors, two of which with brake
- Ergonomic handles for pushing and guiding
- Easy access to facilitate maintenance and repair

FUNCTIONAL FEATURES

- Control panel of temperature, time and humidity. Electromechanical (C), electronic with digital display (D) or electronic with LCD touch-screen (E)
- Simplified, user-friendly controls
- Operating temperature 30°C ÷ 160°C
- Intelligent temperature decrease in the cavity at the end of the regenerating cycle allows a perfect warm holding (only for D and E versions)
- Manual humidity vent
- Periodic reversal of direction of rotation of the fans for better air distribution
- Concealed water storage tank
- End-of-cycle buzzer
- Chamber with safety thermostat
- Delayed start timer (only for D and E versions)

STANDARD SUPPLY

- Removable GN 1/1 tray racks

OPTIONS & ACCESSORIES

- Single-point core probe (for D and E versions)
- Automatic humidity vent (Climachef - only for D and E versions)
- Multipoint core probe (only for D and E versions)
- Speedgrade fan speed reduction system (only for D and E versions)
- USB port saving device HACCP (only for D and E versions)
- Trays
- Grids
- Side racks 600x400
- Needle core probe (only for D and E versions)
- One Touch software
- Opposite side opening
- Glass door and lighting

TECHNICAL INSTALLATION DIAGRAM

Electricity supply
cable inlet 

Adjustable vent for
excess humidity 

Chamber drain
and condensation
drain tray 

Softened
water tank 

Important - Drawing and
dimensions refer to the
standard version.
They may change with the
addition of accessories
or options.

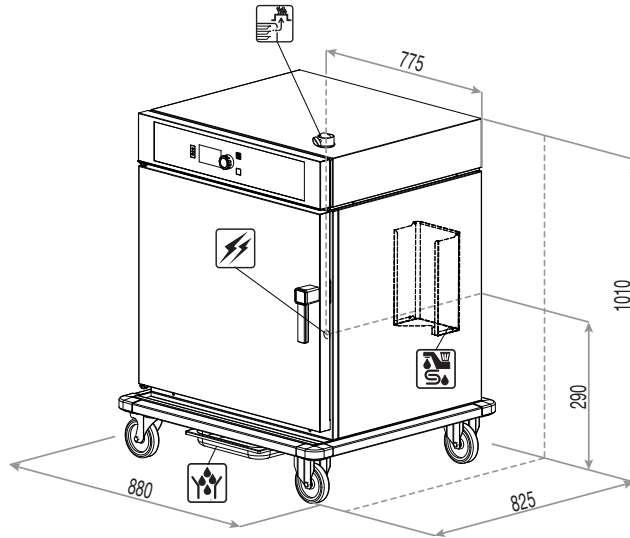

Overall dimensions
(W x D x H) - mm

880 x 825 x 1010h

Trays capacity

5 x GN 1/1
or 600 x 400

Distance
[mm]

93

Plates capacity
(tray racks GN1/1)

10 ø 200-260
5 ø 270-320

Power supply

AC 220-240V 50/60Hz

**Working
temperature [°C]**

30 ÷ 160

**Product max
capacity [Kg]**

18

**Total input
[kW]**

3,45 (230V)

**Amps.
[A]**

15 (230V)

**Net weight
[Kg]**

77

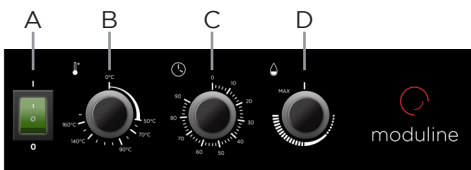

C Version

- A ON/OFF switch
- B Cavity temperature knob
- C Time setting knob
- D Cavity humidity control knob

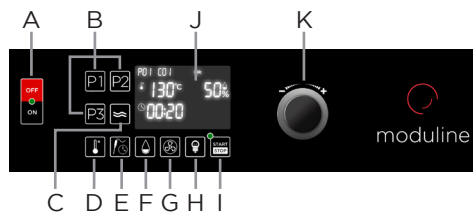

D Version

- A ON/OFF switch
- B Pre-set program keys
- C Holding function key
- D Cavity temperature control key
- E Time / core probe control key
- F Cavity humidity control key
- G Fan speed control key (optional)
- H Cavity light key
- I Start/stop key
- J Display
- K Encoder knob

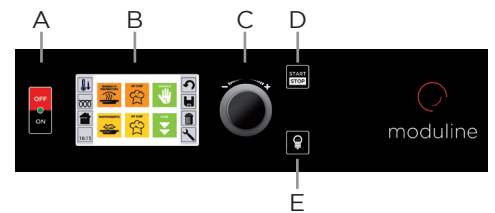

E Version

- A ON/OFF switch
- B Display Touch Screen
- C Setting knob and select "ENTER"
- D "START/STOP" button
- E Chamber light button



REThERM RRT061C/D/E

Regeneration oven
to reheat refrigerated
food (+3°C)

CONSTRUCTION FEATURES

- Tightness chamber with radiused corners
- All-around rubber bumpers
- Total thermic insulation with rock or glass wool
- Long lasting front seal, made up of food-grade and high-heat resistant silicone
- Removable side racks to facilitate cleaning
- Internal drain for easy cleaning
- Ventilated heating provided by high efficiency protected heating elements
- Snap-shut door
- Mounted on four 125mm diameter castors, two of which with brake
- Ergonomic handles for pushing and guiding
- Easy access to facilitate maintenance and repair

FUNCTIONAL FEATURES

- Control panel of temperature, time and humidity. Electromechanical (C), electronic with digital display (D) or electronic with LCD touch-screen (E)
- Simplified, user-friendly controls
- Operating temperature 30°C ÷ 160°C
- Intelligent temperature decrease in the cavity at the end of the regenerating cycle allows a perfect warm holding (only for D and E versions)
- Manual humidity vent
- Periodic reversal of direction of rotation of the fans for better air distribution
- Concealed water storage tank
- End-of-cycle buzzer
- Chamber with safety thermostat
- Delayed start timer (only for D and E versions)

STANDARD SUPPLY

- Removable GN 1/1 tray racks

OPTIONS & ACCESSORIES

- Single-point core probe (for D and E versions)
- Automatic humidity vent (Climachef - only for D and E versions)
- Multipoint core probe (only for D and E versions)
- Speedgrade fan speed reduction system (only for D and E versions)
- USB port saving device HACCP (only for D and E versions)
- Trays
- Grids
- Side racks 600x400
- Needle core probe (only for D and E versions)
- One Touch software
- Opposite side opening
- Glass door and lighting

TECHNICAL INSTALLATION DIAGRAM

Electricity supply
cable inlet 

Adjustable vent for
excess humidity 

Chamber drain
and condensation
drain tray 

Softened
water tank 

Important - Drawing and
dimensions refer to the
standard version.
They may change with the
addition of accessories
or options.

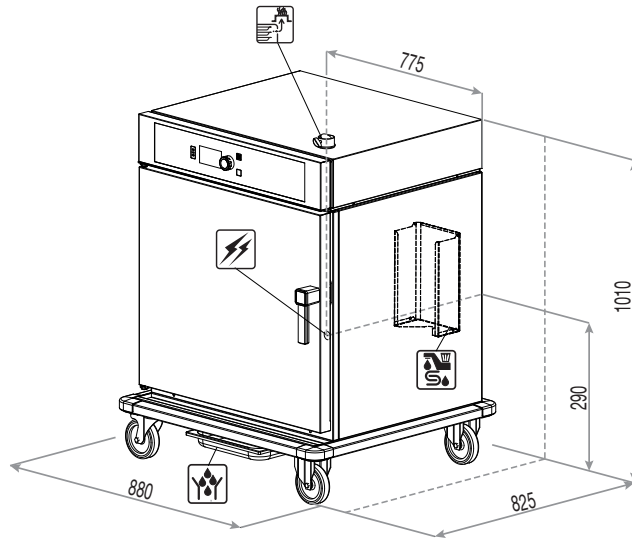

Overall dimensions
(W x D x H) - mm

880 x 825 x 1010h

Trays capacity

6 x GN 1/1
or 600 x 400

Distance
[mm]

78

Plates capacity
(tray racks GN1/1)

12 ø 200-260
6 ø 270-320

Power supply

AC 220-240V 50/60Hz

**Working
temperature [°C]**

30 ÷ 160

**Product max
capacity [Kg]**

22

**Total input
[kW]**

3,45 (230V)

**Amps.
[A]**

15 (230V)

**Net weight
[Kg]**

77

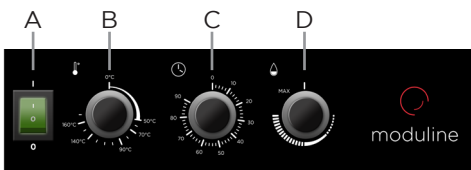

C Version

- A ON/OFF switch
- B Cavity temperature knob
- C Time setting knob
- D Cavity humidity control knob

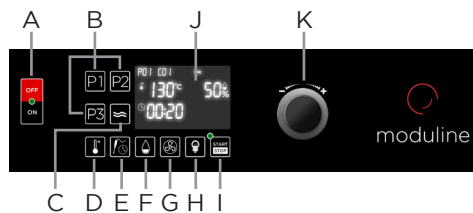

D Version

- A ON/OFF switch
- B Pre-set program keys
- C Holding function key
- D Cavity temperature control key
- E Time / core probe control key
- F Cavity humidity control key
- G Fan speed control key (optional)
- H Cavity light key
- I Start/stop key
- J Display
- K Encoder knob

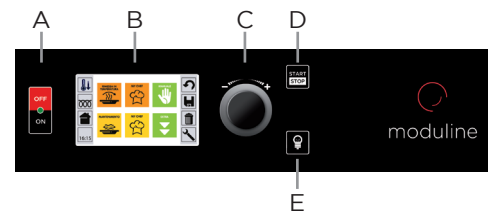

E Version

- A ON/OFF switch
- B Display Touch Screen
- C Setting knob and select "ENTER"
- D "START/STOP" button
- E Chamber light button



REThERM RRT081C/D/E

Regeneration oven
to reheat refrigerated
food (+3°C)

CONSTRUCTION FEATURES

- Tightness chamber with radiused corners
- All-around rubber bumpers
- Total thermic insulation with rock or glass wool
- Long lasting front seal, made up of food-grade and high-heat resistant silicone
- Removable side racks to facilitate cleaning
- Internal drain for easy cleaning
- Ventilated heating provided by high efficiency protected heating elements
- Snap-shut door
- Mounted on four 125mm diameter castors, two of which with brake
- Ergonomic handles for pushing and guiding
- Easy access to facilitate maintenance and repair

FUNCTIONAL FEATURES

- Control panel of temperature, time and humidity. Electromechanical (C), electronic with digital display (D) or electronic with LCD touch-screen (E)
- Simplified, user-friendly controls
- Operating temperature 30°C ÷ 160°C
- Intelligent temperature decrease in the cavity at the end of the regenerating cycle allows a perfect warm holding (only for D and E versions)
- Manual humidity vent
- Periodic reversal of direction of rotation of the fans for better air distribution
- Concealed water storage tank
- End-of-cycle buzzer
- Chamber with safety thermostat
- Delayed start timer (only for D and E versions)

STANDARD SUPPLY

- Removable GN 1/1 tray racks

OPTIONS & ACCESSORIES

- Single-point core probe (only for D and E versions)
- Automatic humidity vent (Climachef - only for D and E versions)
- Multipoint core probe (only for D and E versions)
- Speedgrade fan speed reduction system (only for D and E versions)
- USB port saving device HACCP (only for D and E versions)
- Trays
- Grids
- Side racks 600x400
- Needle core probe (only for D and E versions)
- One Touch software
- Opposite side opening
- Glass door and lighting

TECHNICAL INSTALLATION DIAGRAM

Electricity supply
cable inlet 

Adjustable vent for
excess humidity 

Chamber drain
and condensation
drain tray 

Softened
water tank 

Important - Drawing and
dimensions refer to the
standard version.
They may change with the
addition of accessories
or options.

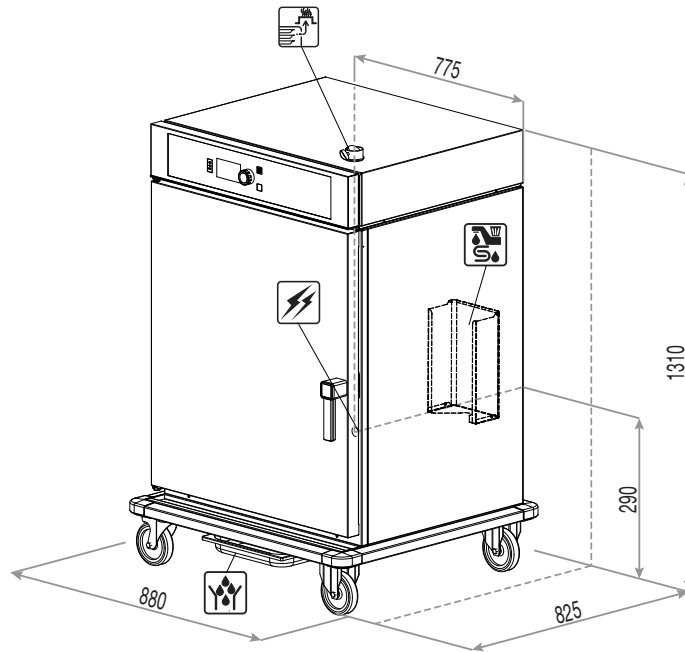

Overall dimensions (W x D x H) - mm	880 x 825 x 1310h
Trays capacity	8 x GN 1/1 or 600 x 400
Distance [mm]	96
Plates capacity (tray racks GN1/1)	16 ø 200-260 8 ø 270-320
Power supply	380-415V 3N 50/60Hz

Working temperature [°C]	30 ÷ 160
Product max capacity [Kg]	29
Total input [kW]	6,8 (400V)
Amps. [A]	9,9 (400V)
Net weight [Kg]	102

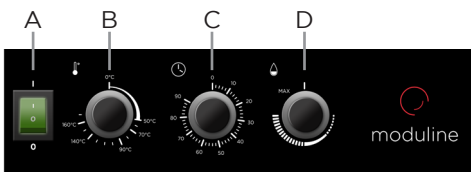

C Version

- A ON/OFF switch
- B Cavity temperature knob
- C Time setting knob
- D Cavity humidity control knob

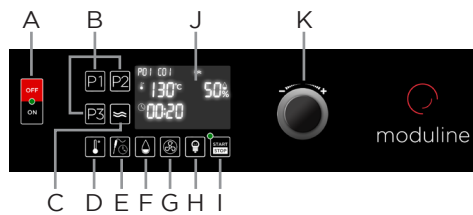

D Version

- A ON/OFF switch
- B Pre-set program keys
- C Holding function key
- D Cavity temperature control key
- E Time / core probe control key
- F Cavity humidity control key
- G Fan speed control key (optional)
- H Cavity light key
- I Start/stop key
- J Display
- K Encoder knob

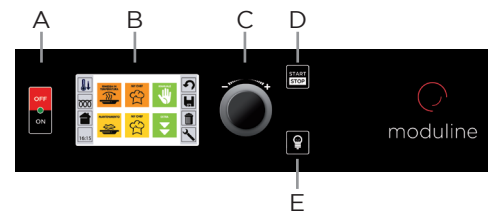

E Version

- A ON/OFF switch
- B Display Touch Screen
- C Setting knob and select "ENTER"
- D "START/STOP" button
- E Chamber light button



REThERM RRT101C/D/E

Regeneration oven
to reheat refrigerated
food (+3°C)

CONSTRUCTION FEATURES

- Tightness chamber with radiused corners
- All-around rubber bumpers
- Total thermic insulation with rock or glass wool
- Long lasting front seal, made up of food-grade and high-heat resistant silicone
- Removable side racks to facilitate cleaning
- Internal drain for easy cleaning
- Ventilated heating provided by high efficiency protected heating elements
- Snap-shut door
- Mounted on four 125mm diameter castors, two of which with brake
- Ergonomic handles for pushing and guiding
- Easy access to facilitate maintenance and repair

FUNCTIONAL FEATURES

- Control panel of temperature, time and humidity. Electromechanical (C), electronic with digital display (D) or electronic with LCD touch-screen (E)
- Simplified, user-friendly controls
- Operating temperature 30°C ÷ 160°C
- Intelligent temperature decrease in the cavity at the end of the regenerating cycle allows a perfect warm holding (only for D and E versions)
- Manual humidity vent
- Periodic reversal of direction of rotation of the fans for better air distribution
- Concealed water storage tank
- End-of-cycle buzzer
- Chamber with safety thermostat
- Delayed start timer (only for D and E versions)

STANDARD SUPPLY

- Removable GN 1/1 tray racks

OPTIONS & ACCESSORIES

- Single-point core probe (only for D and E versions)
- Automatic humidity vent (Climachef - only for D and E versions)
- Multipoint core probe (only for D and E versions)
- Speedgrade fan speed reduction system (only for D and E versions)
- USB port saving device HACCP (only for D and E versions)
- Trays
- Grids
- Side racks 600x400
- Needle core probe (only for D and E versions)
- One Touch software
- Opposite side opening
- Glass door and lighting

TECHNICAL INSTALLATION DIAGRAM

Electricity supply
cable inlet



Adjustable vent for
excess humidity



Chamber drain
and condensation
drain tray



Softened
water tank



Important - Drawing and
dimensions refer to the
standard version.
They may change with the
addition of accessories
or options.

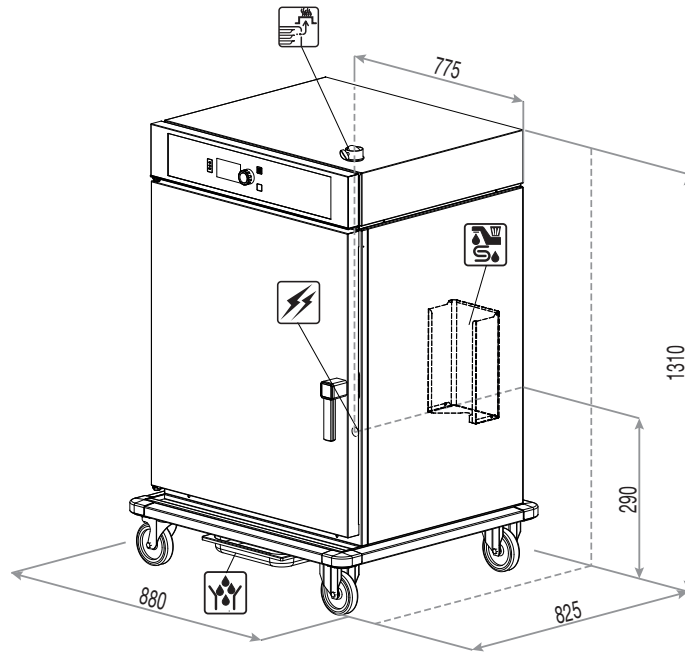

**Overall dimensions
(W x D x H) - mm**

880 x 825 x 1310h

Trays capacity

10 x GN 1/1
or 600 x 400

**Distance
[mm]**

76

**Plates capacity
(tray racks GN1/1)**

20 ø 200-260
10 ø 270-320

Power supply

380-415V 3N 50/60Hz

**Working
temperature [°C]**

30 ÷ 160

**Product max
capacity [Kg]**

36

**Total input
[kW]**

6,8 (400V)

**Amps.
[A]**

9,9 (400V)

**Net weight
[Kg]**

102

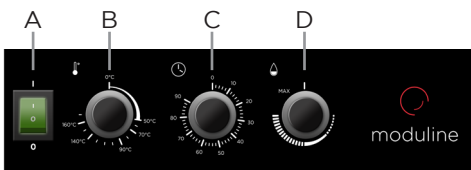

C Version

- A ON/OFF switch
- B Cavity temperature knob
- C Time setting knob
- D Cavity humidity control knob

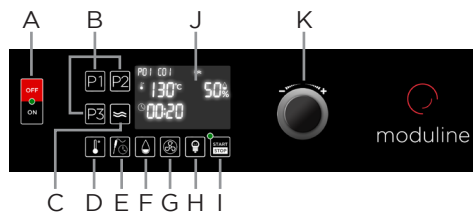

D Version

- A ON/OFF switch
- B Pre-set program keys
- C Holding function key
- D Cavity temperature control key
- E Time / core probe control key
- F Cavity humidity control key
- G Fan speed control key (optional)
- H Cavity light key
- I Start/stop key
- J Display
- K Encoder knob

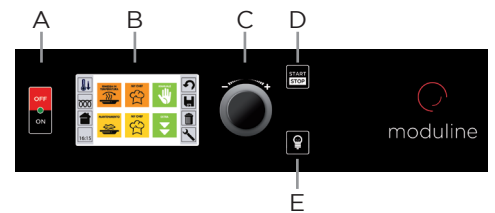

E Version

- A ON/OFF switch
- B Display Touch Screen
- C Setting knob and select "ENTER"
- D "START/STOP" button
- E Chamber light button



REThERM RRT161C/D/E

Regeneration oven
to reheat refrigerated
food (+3°C)

CONSTRUCTION FEATURES

- Tightness chamber with radiused corners
- All-around rubber bumpers
- Total thermic insulation with rock or glass wool
- Long lasting front seal, made up of food-grade and high-heat resistant silicone
- Double door to reduce mostly the drop in temperature at opening
- Removable side racks to facilitate cleaning
- Internal drain for easy cleaning
- Ventilated heating provided by high efficiency protected heating elements
- Snap-shut door
- Mounted on four 150mm diameter castors, two of which with brake
- Ergonomic handles for pushing and guiding
- Easy access to facilitate maintenance and repair

FUNCTIONAL FEATURES

- Control panel of temperature, time and humidity. Electromechanical (C), electronic with digital display (D) or electronic with LCD touch-screen (E)
- Simplified, user-friendly controls
- Operating temperature 30°C ÷ 160°C
- Intelligent temperature decrease in the cavity at the end of the regenerating cycle allows a perfect warm holding (only for D and E versions)
- Manual humidity vent
- Periodic reversal of direction of rotation of the fans for better air distribution
- Concealed water storage tank
- End-of-cycle buzzer
- Chamber with safety thermostat
- Delayed start timer (only for D and E versions)

STANDARD SUPPLY

- Removable GN 1/1 tray racks

OPTIONS & ACCESSORIES

- Single-point core probe (only for D and E versions)
- Automatic humidity vent (Climachef - only for D and E versions)
- Multipoint core probe (only for D and E versions)
- Speedgrade fan speed reduction system (only for D and E versions)
- USB port saving device HACCP (only for D and E versions)
- Trays
- Grids
- Side racks 600x400
- Needle core probe (only for D and E versions)
- One Touch software
- Opposite side opening
- Glass door and lighting

TECHNICAL INSTALLATION DIAGRAM

Electricity supply
cable inlet 

Adjustable vent for
excess humidity 

Chamber drain
and condensation
drain tray 

Softened
water tank 

Important - Drawing and
dimensions refer to the
standard version.
They may change with the
addition of accessories
or options.

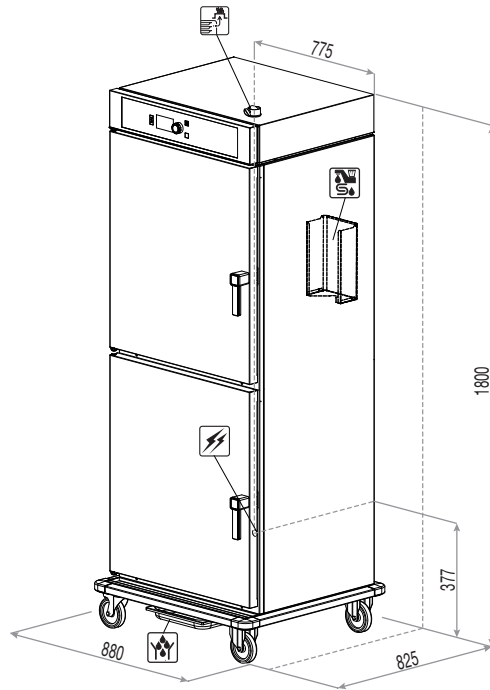

Overall dimensions (W x D x H) - mm	880 x 825 x 1800h
Trays capacity	16 x GN 1/1 or 600x400
Distance [mm]	72
Plates capacity	32 ø 200-260 16 ø 270-320
Power supply	380-415V 3N 50/60Hz

Working temperature [°C]	30 ÷ 160
Product max capacity [Kg]	58
Total input [kW]	6,8 (400V)
Amps. [A]	9,9 (400V)
Net weight [Kg]	135

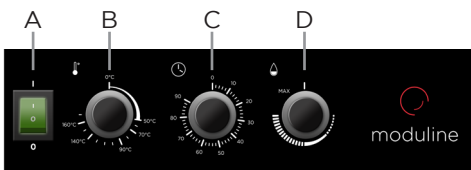

C Version

- A ON/OFF switch
- B Cavity temperature knob
- C Time setting knob
- D Cavity humidity control knob

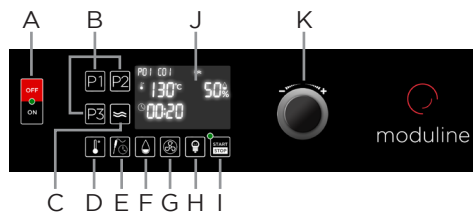

D Version

- A ON/OFF switch
- B Pre-set program keys
- C Holding function key
- D Cavity temperature control key
- E Time / core probe control key
- F Cavity humidity control key
- G Fan speed control key (optional)
- H Cavity light key
- I Start/stop key
- J Display
- K Encoder knob

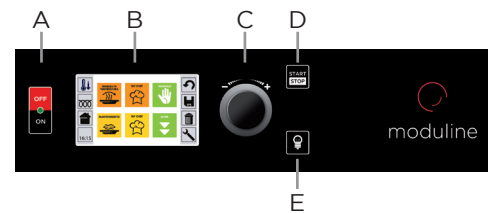

E Version

- A ON/OFF switch
- B Display Touch Screen
- C Setting knob and select "ENTER"
- D "START/STOP" button
- E Chamber light button



RE THERM RRT112C/D/E

Regeneration oven
to reheat refrigerated
food (+3°C)

CONSTRUCTION FEATURES

- Tightness chamber with radiused corners
- All-around rubber bumpers
- Total thermic insulation with rock or glass wool
- Long lasting front seal, made up of food-grade and high-heat resistant silicone
- Removable side racks to facilitate cleaning
- Internal drain for easy cleaning
- Ventilated heating provided by high efficiency protected heating elements
- Snap-shut door
- Mounted on four 125mm diameter castors, two of which with brake
- Ergonomic handles for pushing and guiding
- Easy access to facilitate maintenance and repair

FUNCTIONAL FEATURES

- Control panel of temperature, time and humidity. Electromechanical (C), electronic with digital display (D) or electronic with LCD touch-screen (E)
- Simplified, user-friendly controls
- Operating temperature 30°C ÷ 160°C
- Intelligent temperature decrease in the cavity at the end of the regenerating cycle allows a perfect warm holding (only for D and E versions)
- Manual humidity vent
- Periodic reversal of direction of rotation of the fans for better air distribution
- Concealed water storage tank
- End-of-cycle buzzer
- Chamber with safety thermostat
- Delayed start timer (only for D and E versions)

STANDARD SUPPLY

- Removable GN 2/1 or GN 1/1 tray racks

OPTIONS & ACCESSORIES

- Single-point core probe (for D and E versions)
- Automatic humidity vent (Climachef - only for D and E versions)
- Multipoint core probe (only for D and E versions)
- Speedgrade fan speed reduction system (only for D and E versions)
- USB port saving device HACCP (only for D and E versions)
- Trays
- Grids
- Needle core probe (only for D and E versions)
- One Touch software
- Glass door and lighting

TECHNICAL INSTALLATION DIAGRAM

Electricity supply
cable inlet



Adjustable vent for
excess humidity



Chamber drain
and condensation
drain tray



Softened
water tank



Important - Drawing and
dimensions refer to the
standard version.
They may change with the
addition of accessories
or options.

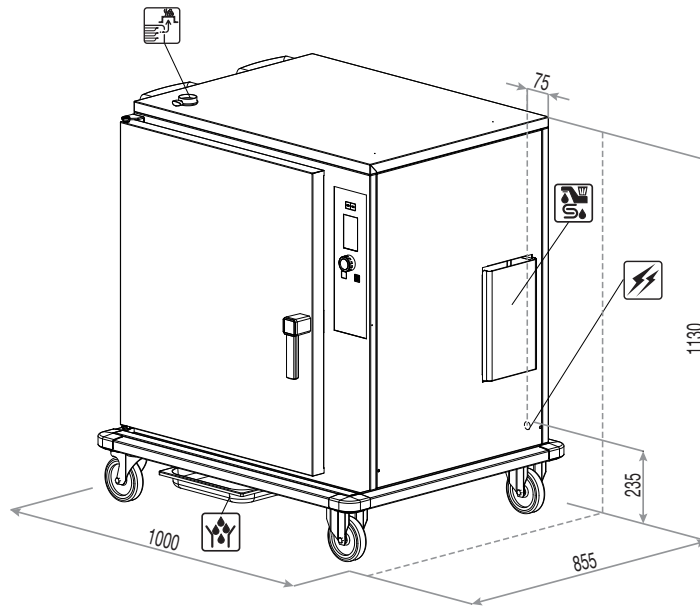

**Overall dimensions
(W x D x H) - mm**

1000 x 855 x 1130h

Trays capacity

10 x GN 2/1
20 x GN 1/1

**Distance
[mm]**

76

**Plates capacity
(tray racks GN1/1)**

40 ø 200-260
20 ø 270-320

Power supply

380-415V 3N 50/60Hz

**Working
temperature [°C]**

30 ÷ 160

**Product max
capacity [Kg]**

72

**Total input
[kW]**

6,8 (400V)

**Amps.
[A]**

9,9 (400V)

**Net weight
[Kg]**

107

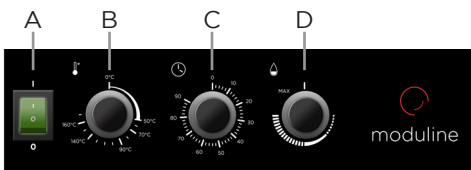

C Version

- A ON/OFF switch
- B Cavity temperature knob
- C Time setting knob
- D Cavity humidity control knob

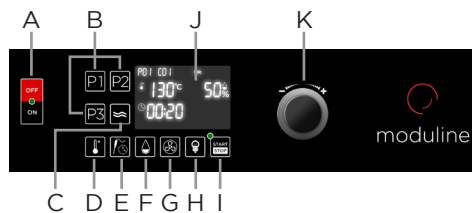

D Version

- A ON/OFF switch
- B Pre-set program keys
- C Holding function key
- D Cavity temperature control key
- E Time / core probe control key
- F Cavity humidity control key
- G Fan speed control key (optional)
- H Cavity light key
- I Start/stop key
- J Display
- K Encoder knob

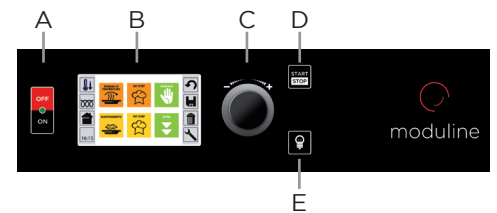

E Version

- A ON/OFF switch
- B Display Touch Screen
- C Setting knob and select "ENTER"
- D "START/STOP" button
- E Chamber light button



REThERM RRT153C/D/E

Regeneration oven
to reheat refrigerated
food (+3°C)

CONSTRUCTION FEATURES

- Tightness chamber with radiused corners
- All-around rubber bumpers
- Total thermic insulation with rock or glass wool
- Long lasting front seal, made up of food-grade and high-heat resistant silicone
- Double door to reduce mostly the drop in temperature at opening
- Removable side racks to facilitate cleaning
- Internal drain for easy cleaning
- Ventilated heating provided by high efficiency protected heating elements
- Snap-shut door
- Mounted on four 150mm diameter castors, two of which with brake
- Ergonomic handles for pushing and guiding
- Easy access to facilitate maintenance and repair

FUNCTIONAL FEATURES

- Control panel of temperature, time and humidity. Electromechanical (C), electronic with digital display (D) or electronic with LCD touch-screen (E)
- Simplified, user-friendly controls
- Operating temperature 30°C ÷ 160°C
- Intelligent temperature decrease in the cavity at the end of the regenerating cycle allows a perfect warm holding (only for D and E versions)
- Manual humidity vent
- Periodic reversal of direction of rotation of the fans for better air distribution
- Concealed water storage tank
- End-of-cycle buzzer
- Chamber with safety thermostat
- Delayed start timer (only for D and E versions)

STANDARD SUPPLY

- Removable GN 2/1 and GN 1/1 tray racks

OPTIONS & ACCESSORIES

- Single-point core probe (only for D and E versions)
- Automatic humidity vent (Climachef - only for D and E versions)
- Multipoint core probe (only for D and E versions)
- Speedgrade fan speed reduction system (only for D and E versions)
- USB port saving device HACCP (only for D and E versions)
- Trays
- Grids
- Needle core probe (only for D and E versions)
- One Touch software
- Glass door and lighting
- Side racks GN 2/1 for 64 plates ø 280mm

TECHNICAL INSTALLATION DIAGRAM

Electricity supply cable inlet 

Adjustable vent for excess humidity 

Chamber drain and condensation drain tray 

Softened water tank 

Important - Drawing and dimensions refer to the standard version. They may change with the addition of accessories or options.

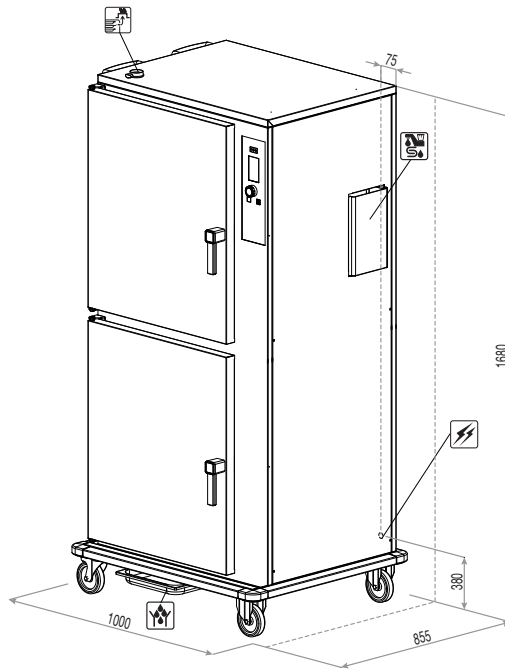

Overall dimensions (W x D x H) - mm	1000 x 855 x 1680h
Trays capacity	16 x GN 2/1 32 x GN 1/1
Distance [mm]	72
Plates capacity	64 ø 200-260 32 ø 270-320
Power supply	380-415V 3N 50/60Hz

Working temperature [°C]	30 ÷ 160
Product max capacity [Kg]	115
Total input [kW]	10,15 (400V)
Amps. [A]	14,7 (400V)
Net weight [Kg]	143

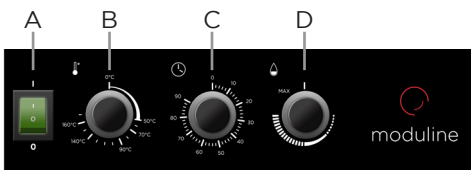

C Version

- A ON/OFF switch
- B Cavity temperature knob
- C Time setting knob
- D Cavity humidity control knob

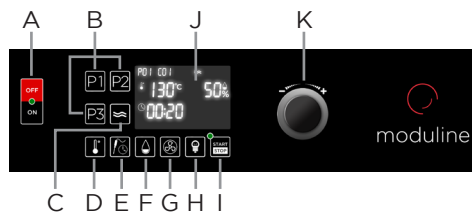

D Version

- A ON/OFF switch
- B Pre-set program keys
- C Holding function key
- D Cavity temperature control key
- E Time / core probe control key
- F Cavity humidity control key
- G Fan speed control key (optional)
- H Cavity light key
- I Start/stop key
- J Display
- K Encoder knob

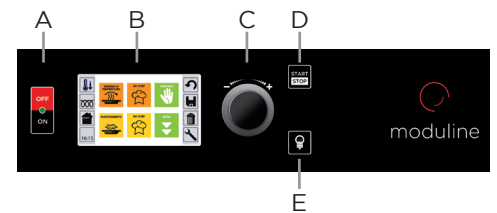

E Version

- A ON/OFF switch
- B Display Touch Screen
- C Setting knob and select "ENTER"
- D "START/STOP" button
- E Chamber light button



REThERM RRT162C/D/E

Regeneration oven
to reheat refrigerated
food (+3°C)

CONSTRUCTION FEATURES

- Tightness chamber with radiused corners
- All-around rubber bumpers
- Total thermic insulation with rock or glass wool
- Long lasting front seal, made up of food-grade and high-heat resistant silicone
- Double door to reduce mostly the drop in temperature at opening
- Removable side racks to facilitate cleaning
- Internal drain for easy cleaning
- Ventilated heating provided by high efficiency protected heating elements
- Snap-shut door
- Mounted on four 150mm diameter castors, two of which with brake
- Ergonomic handles for pushing and guiding
- Easy access to facilitate maintenance and repair

FUNCTIONAL FEATURES

- Control panel of temperature, time and humidity. Electromechanical (C), electronic with digital display (D) or electronic with LCD touch-screen (E)
- Simplified, user-friendly controls
- Operating temperature 30°C ÷ 160°C
- Intelligent temperature decrease in the cavity at the end of the regenerating cycle allows a perfect warm holding (only for D and E versions)
- Manual humidity vent
- Periodic reversal of direction of rotation of the fans for better air distribution
- Concealed water storage tank
- End-of-cycle buzzer
- Chamber with safety thermostat
- Delayed start timer (only for D and E versions)

STANDARD SUPPLY

- Removable GN 2/1 tray racks

OPTIONS & ACCESSORIES

- Single-point core probe (only for D and E versions)
- Automatic humidity vent (Climachef - only for D and E versions)
- Multipoint core probe (only for D and E versions)
- Speedgrade fan speed reduction system (only for D and E versions)
- USB port saving device HACCP (only for D and E versions)
- Trays
- Grids
- Needle core probe (only for D and E versions)
- One Touch software
- Opposite side opening
- Glass door and lighting

TECHNICAL INSTALLATION DIAGRAM

Electricity supply
cable inlet 

Adjustable vent for
excess humidity 

Chamber drain
and condensation
drain tray 

Softened
water tank 

Important - Drawing and
dimensions refer to the
standard version.
They may change with the
addition of accessories
or options.

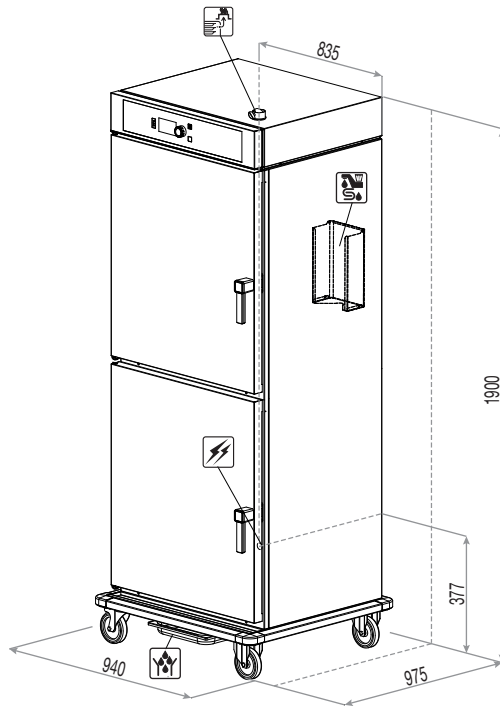

Overall dimensions
(W x D x H) - mm

940 x 975 x 1900h

Trays capacity

16 x GN 2/1

Distance
[mm]

79

Plates capacity

64 ø 200-260
32 ø 270-320

Power supply

380-415V 3N 50/60Hz

**Working
temperature [°C]**

30 ÷ 160

**Product max
capacity [Kg]**

115

**Total input
[kW]**

10,15 (400V)

**Amps.
[A]**

14,7 (400V)

**Net weight
[Kg]**

170

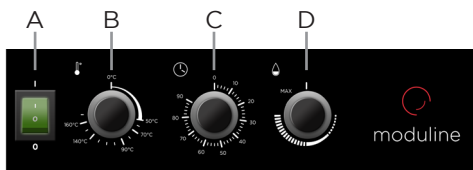

C Version

- A ON/OFF switch
- B Cavity temperature knob
- C Time setting knob
- D Cavity humidity control knob

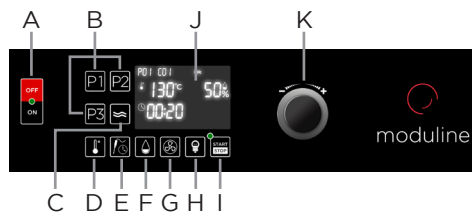

D Version

- A ON/OFF switch
- B Pre-set program keys
- C Holding function key
- D Cavity temperature control key
- E Time / core probe control key
- F Cavity humidity control key
- G Fan speed control key (optional)
- H Cavity light key
- I Start/stop key
- J Display
- K Encoder knob

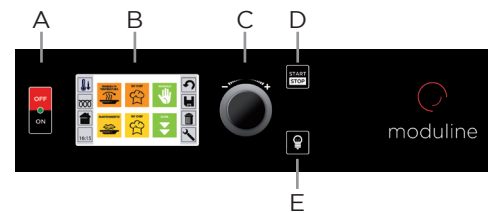

E Version

- A ON/OFF switch
- B Display Touch Screen
- C Setting knob and select "ENTER"
- D "START/STOP" button
- E Chamber light button

По вопросам продаж и поддержки обращайтесь:

Алматы (727)345-47-04
Ангарск (3955)60-70-56
Архангельск (8182)63-90-72
Астрахань (8512)99-46-04
Барнаул (3852)73-04-60
Белгород (4722)40-23-64
Благовещенск (4162)22-76-07
Брянск (4832)59-03-52
Владивосток (423)249-28-31
Владикавказ (8672)28-90-48
Владимир (4922)49-43-18
Волгоград (844)278-03-48
Вологда (8172)26-41-59
Воронеж (473)204-51-73
Екатеринбург (343)384-55-89

Иваново (4932)77-34-06
Ижевск (3412)26-03-58
Иркутск (395)279-98-46
Казань (843)206-01-48
Калининград (4012)72-03-81
Калуга (4842)92-23-67
Кемерово (3842)65-04-62
Киров (8332)68-02-04
Коломна (4966)23-41-49
Кострома (4942)77-07-48
Краснодар (861)203-40-90
Красноярск (391)204-63-61
Курск (4712)77-13-04
Курган (3522)50-90-47
Липецк (4742)52-20-81

Магнитогорск (3519)55-03-13
Москва (495)268-04-70
Мурманск (8152)59-64-93
Набережные Челны (8552)20-53-41
Нижний Новгород (831)429-08-12
Новокузнецк (3843)20-46-81
Ноябрьск (3496)41-32-12
Новосибирск (383)227-86-73
Омск (3812)21-46-40
Орел (4862)44-53-42
Оренбург (3532)37-68-04
Пенза (8412)22-31-16
Петрозаводск (8142)55-98-37
Псков (8112)59-10-37
Пермь (342)205-81-47

Ростов-на-Дону (863)308-18-15
Рязань (4912)46-61-64
Самара (846)206-03-16
Санкт-Петербург (812)309-46-40
Саратов (845)249-38-78
Севастополь (8692)22-31-93
Саранск (8342)22-96-24
Симферополь (3652)67-13-56
Смоленск (4812)29-41-54
Сочи (862)225-72-31
Ставрополь (8652)20-65-13
Сургут (3462)77-98-35
Сыктывкар (8212)25-95-17
Тамбов (4752)50-40-97
Тверь (4822)63-31-35

Тольятти (8482)63-91-07
Томск (3822)98-41-53
Тула (4872)33-79-87
Тюмень (3452)66-21-18
Ульяновск (8422)24-23-59
Улан-Удэ (3012)59-97-51
Уфа (347)229-48-12
Хабаровск (4212)92-98-04
Чебоксары (8352)28-53-07
Челябинск (351)202-03-61
Череповец (8202)49-02-64
Чита (3022)38-34-83
Якутск (4112)23-90-97
Ярославль (4852)69-52-93

Россия +7(495)268-04-70

Казахстан +7(727)345-47-04

Беларусь +(375)257-127-884

Узбекистан +998(71)205-18-59

Киргизия +996(312)96-26-47

эл.почта: meo@nt-rt.ru || сайт: <https://module.nt-rt.ru/>