

Регенерационные печи RRFC версия E

Технические характеристики

По вопросам продаж и поддержки обращайтесь:

Алматы (727)345-47-04
Ангарск (3955)60-70-56
Архангельск (8182)63-90-72
Астрахань (8512)99-46-04
Барнаул (3852)73-04-60
Белгород (4722)40-23-64
Благовещенск (4162)22-76-07
Брянск (4832)59-03-52
Владивосток (423)249-28-31
Владикавказ (8672)28-90-48
Владимир (4922)49-43-18
Волгоград (844)278-03-48
Вологда (8172)26-41-59
Воронеж (473)204-51-73
Екатеринбург (343)384-55-89

Иваново (4932)77-34-06
Ижевск (3412)26-03-58
Иркутск (395)279-98-46
Казань (843)206-01-48
Калининград (4012)72-03-81
Калуга (4842)92-23-67
Кемерово (3842)65-04-62
Киров (8332)68-02-04
Коломна (4966)23-41-49
Кострома (4942)77-07-48
Краснодар (861)203-40-90
Красноярск (391)204-63-61
Курск (4712)77-13-04
Курган (3522)50-90-47
Липецк (4742)52-20-81

Магнитогорск (3519)55-03-13
Москва (495)268-04-70
Мурманск (8152)59-64-93
Набережные Челны (8552)20-53-41
Нижний Новгород (831)429-08-12
Новокузнецк (3843)20-46-81
Ноябрьск (3496)41-32-12
Новосибирск (383)227-86-73
Омск (3812)21-46-40
Орел (4862)44-53-42
Оренбург (3532)37-68-04
Пенза (8412)22-31-16
Петрозаводск (8142)55-98-37
Псков (8112)59-10-37
Пермь (342)205-81-47

Ростов-на-Дону (863)308-18-15
Рязань (4912)46-61-64
Самара (846)206-03-16
Санкт-Петербург (812)309-46-40
Саратов (845)249-38-78
Севастополь (8692)22-31-93
Саранск (8342)22-96-24
Симферополь (3652)67-13-56
Смоленск (4812)29-41-54
Сочи (862)225-72-31
Ставрополь (8652)20-65-13
Сургут (3462)77-98-35
Сыктывкар (8212)25-95-17
Тамбов (4752)50-40-97
Тверь (4822)63-31-35

Тольятти (8482)63-91-07
Томск (3822)98-41-53
Тула (4872)33-79-87
Тюмень (3452)66-21-18
Ульяновск (8422)24-23-59
Улан-Удэ (3012)59-97-51
Уфа (347)229-48-12
Хабаровск (4212)92-98-04
Чебоксары (8352)28-53-07
Челябинск (351)202-03-61
Череповец (8202)49-02-64
Чита (3022)38-34-83
Якутск (4112)23-90-97
Ярославль (4852)69-52-93

Россия +7(495)268-04-70

Казахстан +7(727)345-47-04

Беларусь +(375)257-127-884

Узбекистан +998(71)205-18-59

Киргизия +996(312)96-26-47

эл.почта: meo@nt-rt.ru || сайт: <https://module.nt-rt.ru/>



REThERM RRFC20E

Combined regeneration oven to reheat refrigerated food (+3°C)

CONSTRUCTION FEATURES

- Tightness chamber with radiused corners
- Internal AISI 304 18/10 stainless steel bumpers for trolley's introduction
- Total thermic insulation with rock or glass wool
- Long lasting front seal, made up of food-grade and high-heat resistant silicone
- Ventilated heating provided by high efficiency protected heating elements
- Ventilated cooling provided by stainless steel evaporator
- Ecological compressor units (R452A)
- Door fitted with three point locking system
- Easy access to facilitate maintenance and repair

FUNCTIONAL FEATURES

- Electronic control panel of temperature, time and humidity with LCD touch-screen
- End-of-cycle buzzer
- Simplified, user-friendly control
- Automatic control of the humidity's percentage in the chamber, Climachef system
- Operating temperature: 0°C - 160°C
- Automatic humidity vent
- Chamber can accommodate different sized plate or tray rack transport trolleys
- Chamber with safety thermostat
- Delayed start timer
- Intelligent temperature decrease in the cavity at the end of the regenerating cycle allows a perfect warm holding

STANDARD SUPPLY

- Climachef
- USB port saving device HACCP
- Single-point core probe
- Speedgrade fan speed reduction system

OPTIONS & ACCESSORIES

- GN pans cart
- Plates cart
- Cart thermal cover
- Glass door and lighting
- Multipoint core probe
- External hand shower
- Needle core probe, thin
- One Touch software
- Grids
- Trays

TECHNICAL INSTALLATION DIAGRAM

Electricity supply
cable inlet 

Softened
water inlet 

Adjustable vent for
excess humidity 

Important - Drawing and
dimensions refer to the
standard version.
They may change with the
addition of accessories
or options.

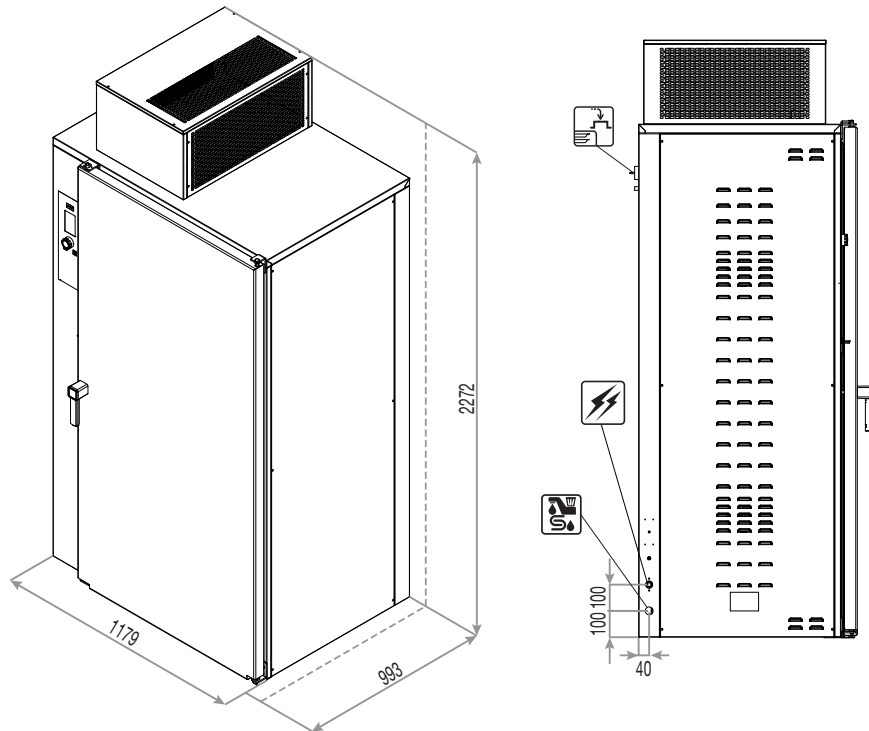

Overall dimensions
(W x D x H) - mm 1179 x 993 x 2272h

Oven interior
(W x D x H) - mm 780 x 695 x 1860h

Trays capacity 20 x GN 1/1 h65

Plates capacity
Plates Ø 230-310 84

Power supply 380-415V 3N 50Hz

Total input
[kW] 12,5 (400V)

Amps.
[A] 18,1 (400V)

Water pressure
[kPa] 150 ÷ 500

**Working
temperature** [°C] 0 ÷ 160

**Product max
capacity** [Kg] 72

Net weight
[Kg] 245

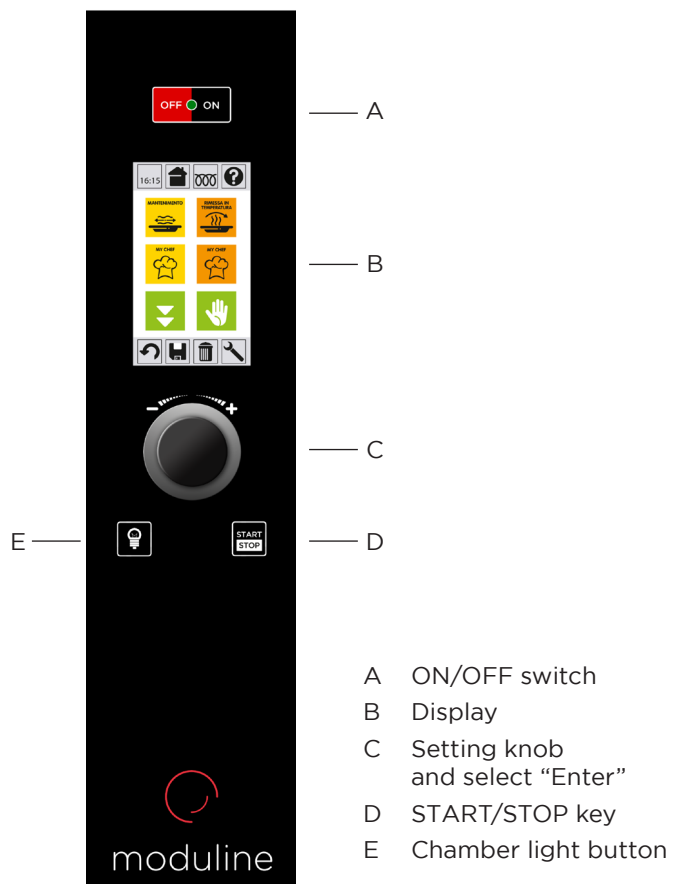

- A ON/OFF switch
- B Display
- C Setting knob
and select "Enter"
- D START/STOP key
- E Chamber light button



REThERM RRFC40E

Combined regeneration oven to reheat refrigerated food (+3°C)

CONSTRUCTION FEATURES

- Tightness chamber with radiused corners
- Internal AISI 304 18/10 stainless steel bumpers for trolley's introduction
- Total thermic insulation with rock or glass wool
- Long lasting front seal, made up of food-grade and high-heat resistant silicone
- Ventilated heating provided by high efficiency protected heating elements
- Ventilated cooling provided by stainless steel evaporator
- Ecological compressor units (R452A)
- Door fitted with three point locking system
- Easy access to facilitate maintenance and repair

FUNCTIONAL FEATURES

- Electronic control panel of temperature, time and humidity with LCD touch-screen
- End-of-cycle buzzer
- Simplified, user-friendly control
- Automatic control of the humidity's percentage in the chamber, Climachef system
- Operating temperature: 0°C - 160°C
- Automatic humidity vent
- Chamber can accommodate different sized plate or tray rack transport trolleys
- Chamber with safety thermostat
- Delayed start timer
- Intelligent temperature decrease in the cavity at the end of the regenerating cycle allows a perfect warm holding,

STANDARD SUPPLY

- Climachef
- USB port saving device HACCP
- Single-point core probe
- Speedgrade fan speed reduction system

OPTIONS & ACCESSORIES

- GN pans cart
- Plates cart
- Cart thermal cover
- Glass door and lighting
- Multipoint core probe
- External hand shower
- Needle core probe, thin
- One Touch software
- Grids
- Trays

TECHNICAL INSTALLATION DIAGRAM

Electricity supply
cable inlet 

Softened
water inlet 

Adjustable vent for
excess humidity 

Important - Drawing and
dimensions refer to the
standard version.
They may change with the
addition of accessories
or options.

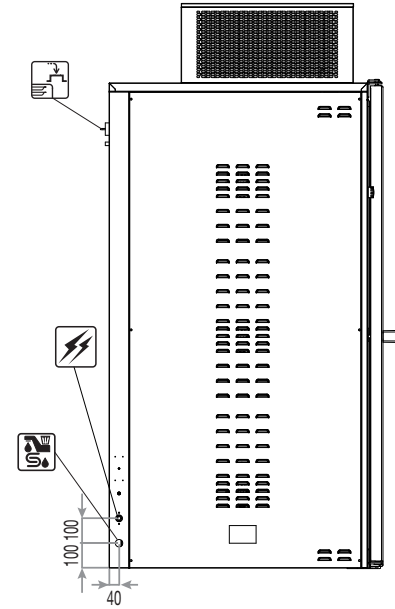
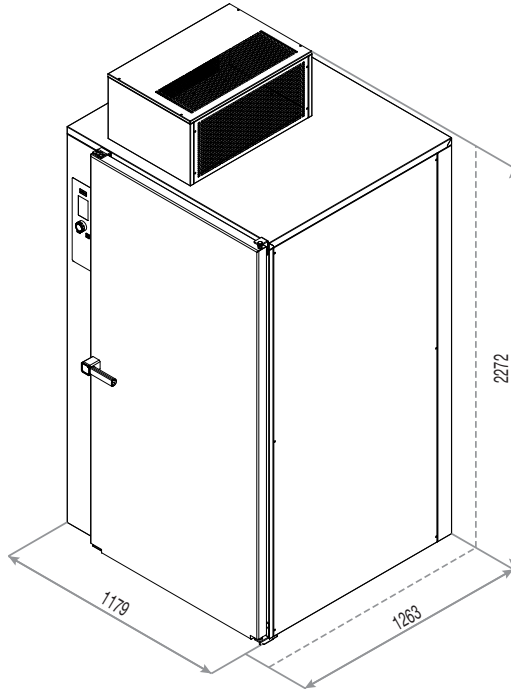

Overall dimensions (W x D x H) - mm	1179 x 1263 x 2272h
Oven interior (W x D x H) - mm	780 x 975 x 1860h
Trays capacity	40 x GN 1/1 h65 20 x GN 2/1 h65
Plates capacity Plates Ø 230-310	126
Power supply	380-415V 3N 50Hz
Total input [kW]	23,2 (400V)
Amps. [A]	33,6 (400V)
Water pressure [kPa]	150 ÷ 500
Working temperature [°C]	0 ÷ 160
Product max capacity [Kg]	144
Net weight [Kg]	290

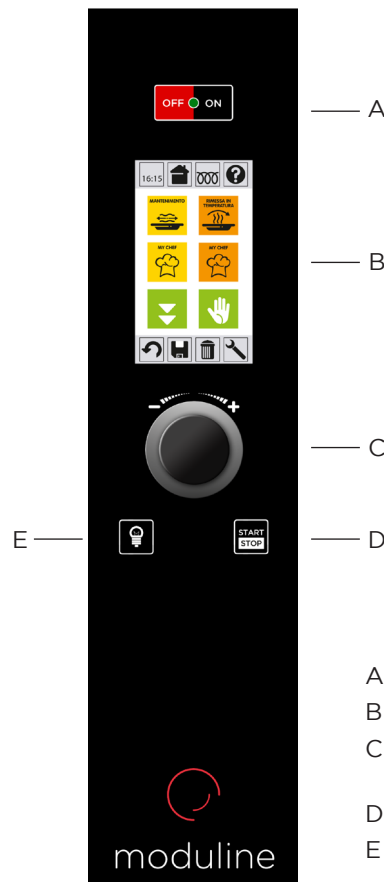

- A ON/OFF switch
- B Display
- C Setting knob
and select "Enter"
- D START/STOP key
- E Chamber light button

moduline

По вопросам продаж и поддержки обращайтесь:

Алматы (727)345-47-04
Ангарск (3955)60-70-56
Архангельск (8182)63-90-72
Астрахань (8512)99-46-04
Барнаул (3852)73-04-60
Белгород (4722)40-23-64
Благовещенск (4162)22-76-07
Брянск (4832)59-03-52
Владивосток (423)249-28-31
Владикавказ (8672)28-90-48
Владимир (4922)49-43-18
Волгоград (844)278-03-48
Вологда (8172)26-41-59
Воронеж (473)204-51-73
Екатеринбург (343)384-55-89

Иваново (4932)77-34-06
Ижевск (3412)26-03-58
Иркутск (395)279-98-46
Казань (843)206-01-48
Калининград (4012)72-03-81
Калуга (4842)92-23-67
Кемерово (3842)65-04-62
Киров (8332)68-02-04
Коломна (4966)23-41-49
Кострома (4942)77-07-48
Краснодар (861)203-40-90
Красноярск (391)204-63-61
Курск (4712)77-13-04
Курган (3522)50-90-47
Липецк (4742)52-20-81

Магнитогорск (3519)55-03-13
Москва (495)268-04-70
Мурманск (8152)59-64-93
Набережные Челны (8552)20-53-41
Нижний Новгород (831)429-08-12
Новокузнецк (3843)20-46-81
Ноябрьск (3496)41-32-12
Новосибирск (383)227-86-73
Омск (3812)21-46-40
Орел (4862)44-53-42
Оренбург (3532)37-68-04
Пенза (8412)22-31-16
Петрозаводск (8142)55-98-37
Псков (8112)59-10-37
Пермь (342)205-81-47

Ростов-на-Дону (863)308-18-15
Рязань (4912)46-61-64
Самара (846)206-03-16
Санкт-Петербург (812)309-46-40
Саратов (845)249-38-78
Севастополь (8692)22-31-93
Саранск (8342)22-96-24
Симферополь (3652)67-13-56
Смоленск (4812)29-41-54
Сочи (862)225-72-31
Ставрополь (8652)20-65-13
Сургут (3462)77-98-35
Сыктывкар (8212)25-95-17
Тамбов (4752)50-40-97
Тверь (4822)63-31-35

Тольятти (8482)63-91-07
Томск (3822)98-41-53
Тула (4872)33-79-87
Тюмень (3452)66-21-18
Ульяновск (8422)24-23-59
Улан-Удэ (3012)59-97-51
Уфа (347)229-48-12
Хабаровск (4212)92-98-04
Чебоксары (8352)28-53-07
Челябинск (351)202-03-61
Череповец (8202)49-02-64
Чита (3022)38-34-83
Якутск (4112)23-90-97
Ярославль (4852)69-52-93

Россия +7(495)268-04-70

Казахстан +7(727)345-47-04

Беларусь +(375)257-127-884

Узбекистан +998(71)205-18-59

Киргизия +996(312)96-26-47

эл.почта: meo@nt-rt.ru || сайт: <https://module.nt-rt.ru/>